

i25-X | i30-X | i35-X Installation Instructions

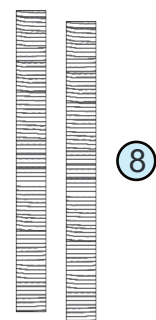

I25-X | I30-X | I35-X ZC

Components

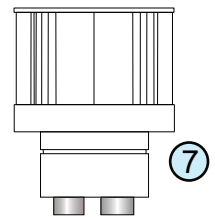
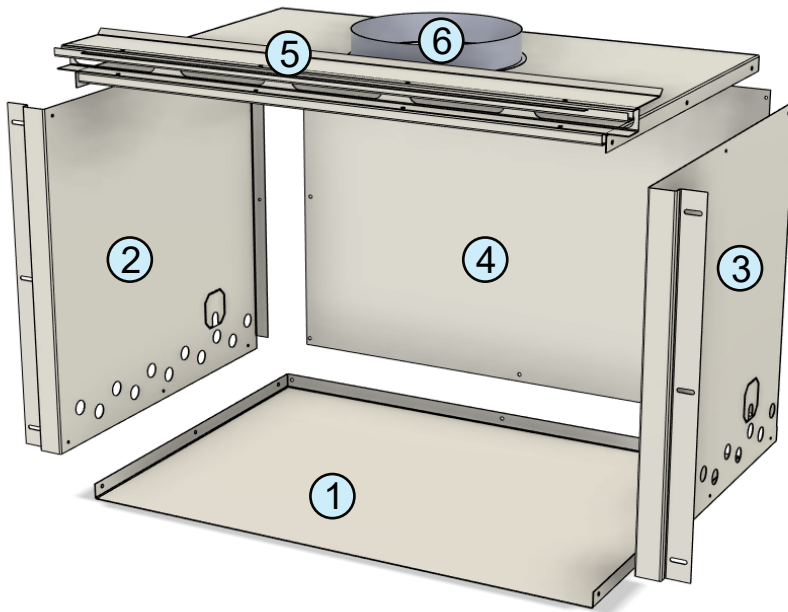

1	Base
2	Left panel
3	Right panel
4	Rear panel
5	Top panel
6	Flue spigot - 8inch
7	Vertical Termination Cowl
8	Flexible flue - 4m
9	8inch Gal pipe to suit required length

PLEASE NOTE:

1. 2x 45 degree bends allowed (max 300mm between bends)
2. 300mm min from firebox top to bottom edge of any timber mantel
3. Zero clearance casing and flue rough in must be prior to plaster

I25-X | I30-X | I35-X ZC

Min. Framing Dimensions



	I25-X	I30-X	I35-X
H	555mm	643mm	735mm
W	740mm	882mm	995mm
D	490mm	536mm	490mm

Framing illustration is a guide only and may vary due to design requirements.

PLEASE NOTE:

1. 2x 45 degree bends allowed (max 300mm between bends)
2. 300mm min from firebox top to bottom edge of any timber mantel
3. Zero clearance casing and flue rough in must be prior to plaster

I25-X | I30-X | I35-X ZC Assembly Instructions

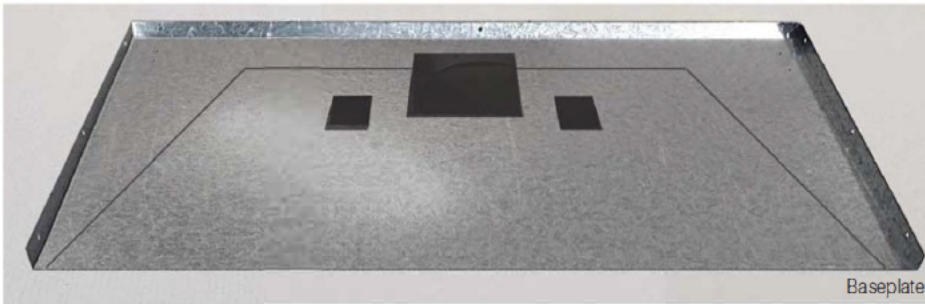

Step 1:

Lay the base panel flat on your working surface, with the flat edge to the front.



Step 2:

Position the side panels (Gas and Electrical on the LEFT), then screw both sides into the base panel using the screws supplied. Ensure the raised channel sections are placed to the front.



Step 3:

The electrical cord feeds through the 'trapdoor' outlet and the black plastic grommet is positioned around the cord. when the unit is inserted into the box, pull the cord tight so the majority of the cord is outside the box.



Step 4:

Position the top plate over the 3 sides (vertical panels fit inside the top plate), line up all pre-drilled holes then screw all panels together.

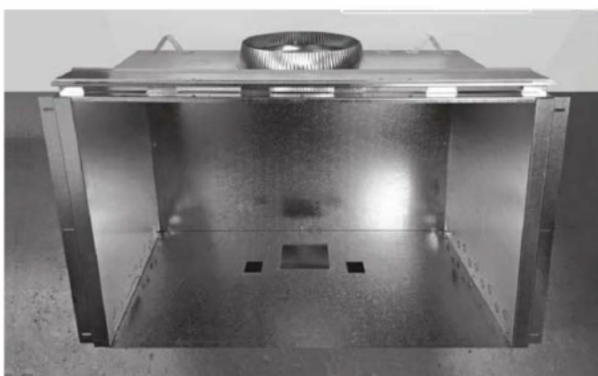

Step 5:

The Zero Clearance box is now fully assembled.

I25-X | I30-X | I35-X ZC Assembly Instructions



Step 6:

Position the galvanized flue over the crimped spigot located on top of the box and fit to spigot using either pop rivets or self-tapping screws.

Step 7:

Attach the flexi flue to the starter collars located on the underside of the flue termination, remembering to mark either the intake or exhaust as the flexi flue may turn when fitting. Lower the flexi flues down the galvanized flue pipe and affix both to their corresponding locations on the fireplace flue starter panel.

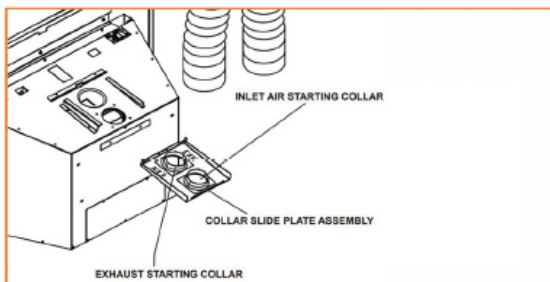
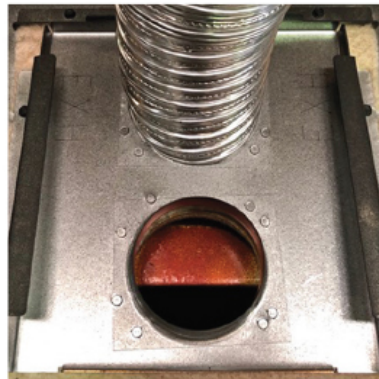
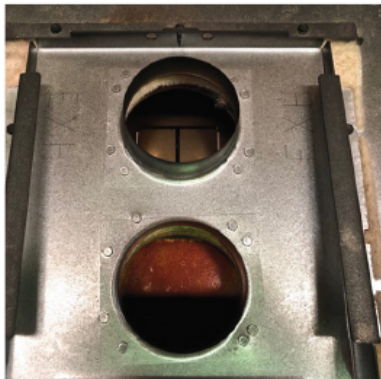
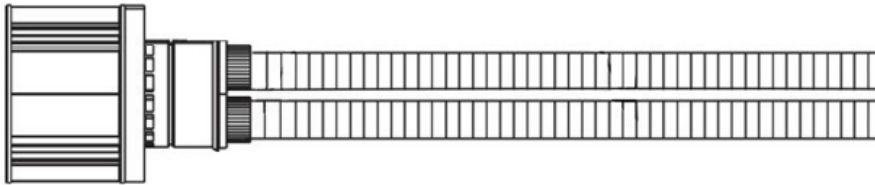

Connecting Vent Pipe

Reference instructions in the termination kit

- Install the two 3" flexi flue pipe(s) down through the gal flue pipe
- Secure each of the pipes to the starter collars using 3 self tapping screws on each

Note: The collar slide plate may be removed from the unit to aid installation - please see instruction manual



Straight Flue Run

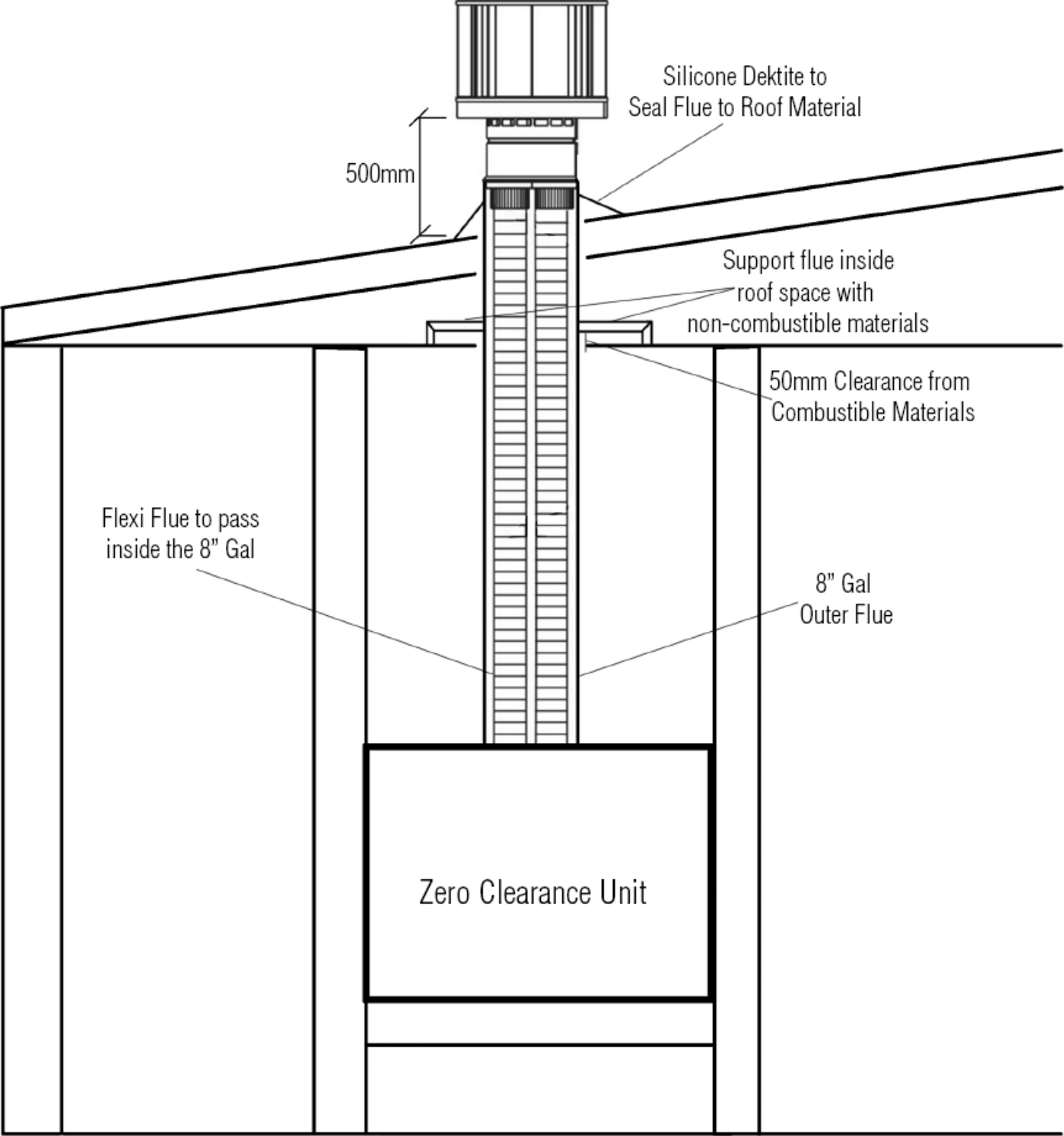

Offset Flue Run

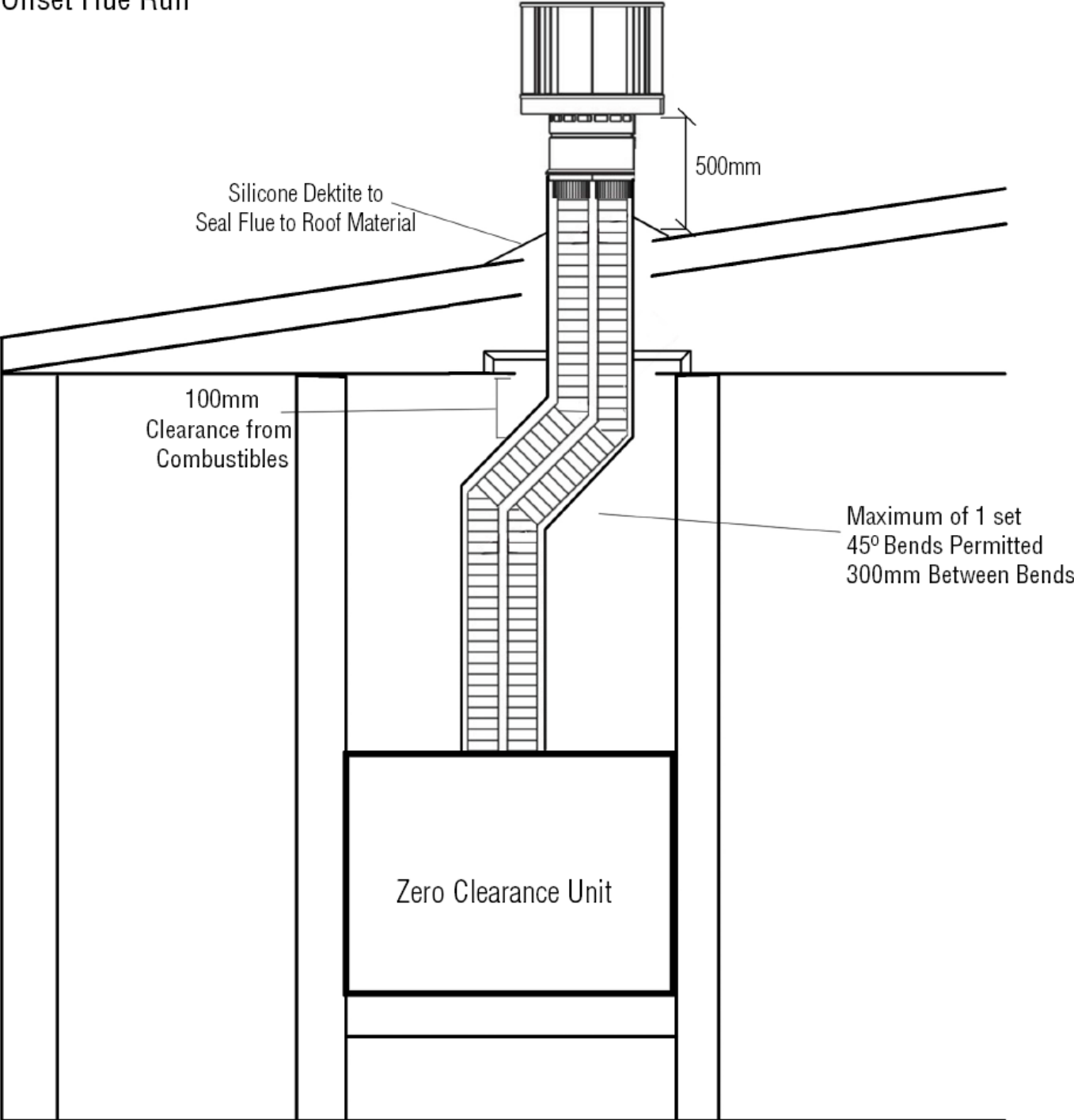

I25-X | I30-X | I35-X ZC Assembly Instructions



Step 9:

Assembly is now complete, unit should now be ready to be installed into the pre-built timber frame (see specifications).

Please Note - Wall to be clad in 13mm Fyrchek or similar

HEAT & GLO

Jetmaster Fireplaces Australia
55 Marrickville Road,
Marrickville, NSW, 2204
www.jetmaster.com.au