

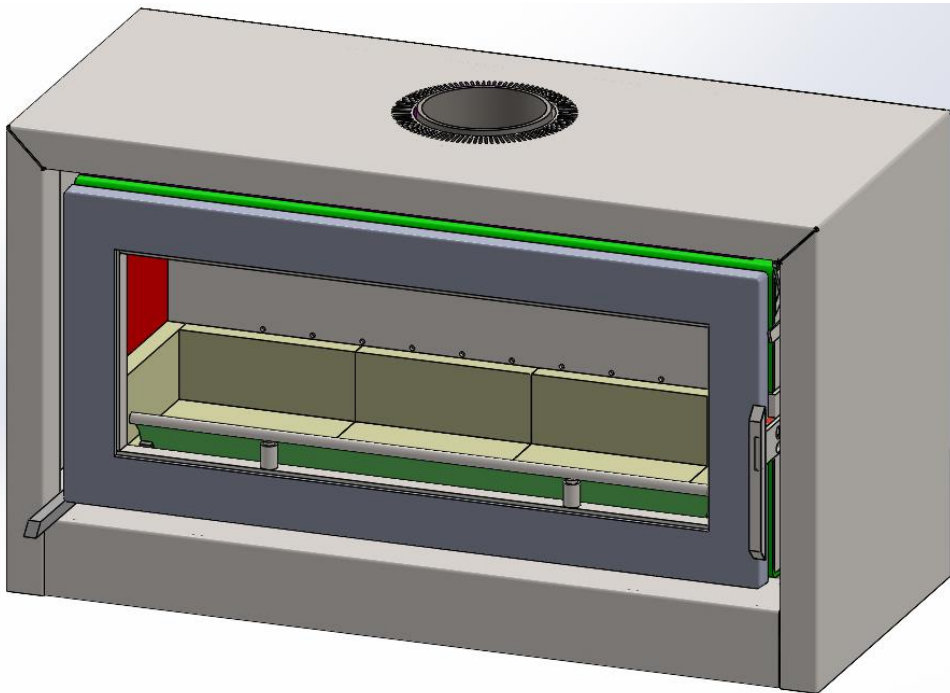

Specialists in fireplace design and manufacture

CELESTIAL 900 FREESTANDING SOFTWOOD **INSTALLATION & OPERATING INSTRUCTIONS**



IMPORTANT:

INSTALLER, PLEASE LEAVE THESE INSTRUCTIONS WITH THE UNIT ON COMPLETION.

10 YEAR FIREBOX WARRANTY

**The firebox is covered by a 10 year warranty.
Other parts are covered by a one year limited warranty.**

Head Office – 13 French Avenue, Brendale, Queensland 4500

Telephone – PH: (07) 3490 5500

Facsimile – FAX: (07) 3490 5520

Website: - www.jetmaster.com.au

Business hours: - Monday to Thursday 7:30am-4:00pm. Friday 7:30am-2:00pm

Email: - sales@jetmaster.com.au

DIMENSIONS

CELESTIAL 900 FREESTANDING WITH METAL CASING

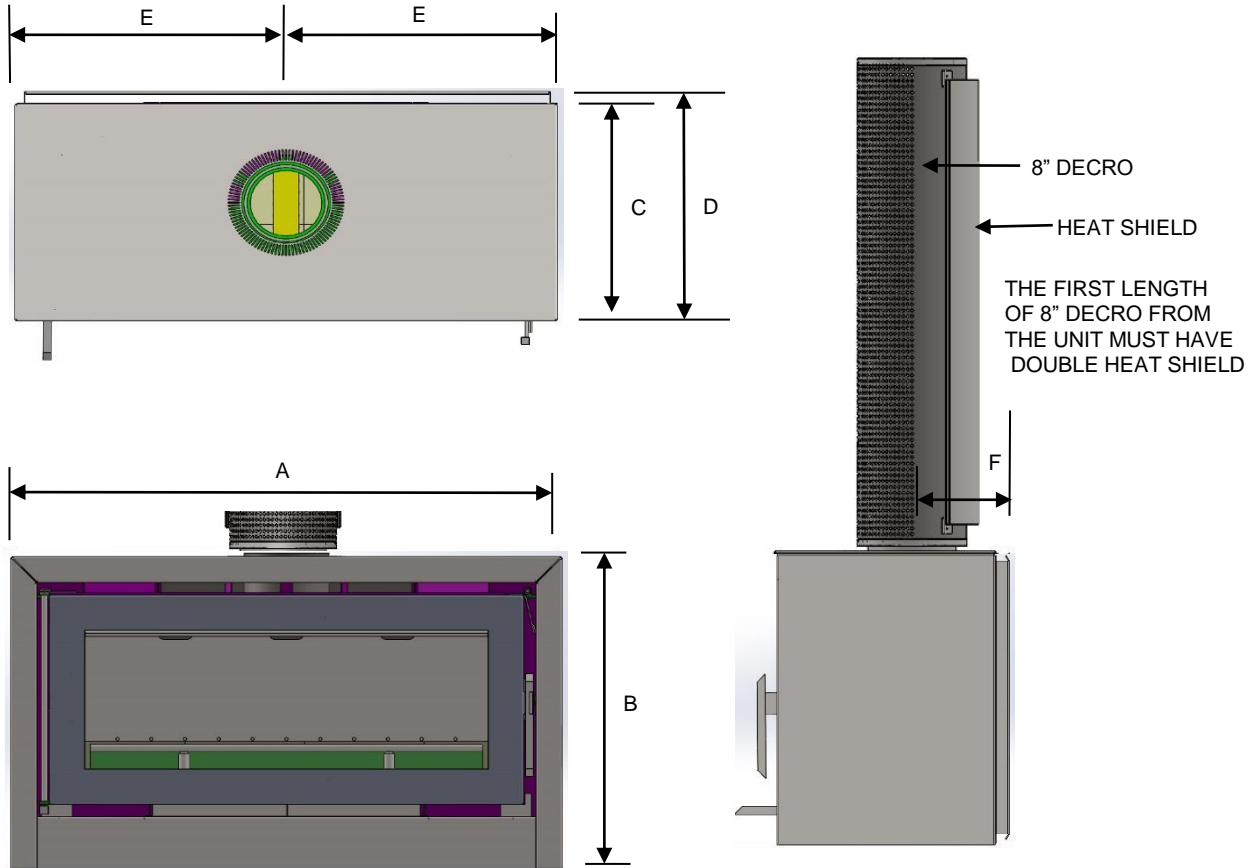

IMPORTANT: ANY APPENDIX F APPROVED FLUE KITS CAN BE USED ON THESE KEMLAN FREESTANDING FIREPLACES AS LONG AS IT COMPLIES WITH THE LABORATORY TESTED HEAT SHIELDING"

	A	B	C	D	E	F	G	H
MEASUREMENTS	1060	602	465	491	530	239	776	268

MINIMUM CLEARANCES FOR THE CELESTIAL 900 FREESTANDING SOLID FUEL APPLIANCE INSTALLED WITH DEFAULT FLUE KIT

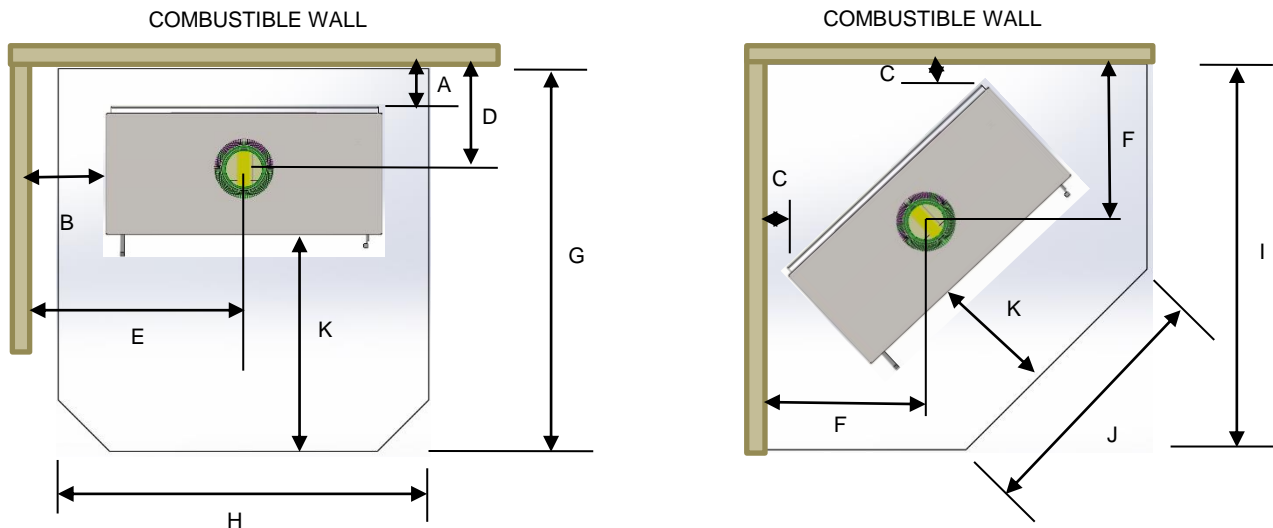

MINIMUM CLEARANCES:

	A	B	C	D	E	F	G	H	I	J	K
MEASUREMENT	100	200	45**	339	730	575	1051	1180	1401	910	460*

*As per Clause 3.3.2 of AS/NZS 2918:2001 for floor protector construction requirements. This measurement only applies when unit is 200mm above floor. (refer hearth measurement drawing if unit is higher than 200mm from floor.)

** This is the minimum allowable distance to any combustable material behind the unit.

Glass viewing area- 776mm wide x 268mm high
Flue pipe- ø150mm – top exit
Shipping weight- 185 kg

All dimensions shown are approximate. Check all dimensions accurately before installation. Before installing refer to the installation instructions.

In line with our policy of continuous improvement, we reserve the right to alter specifications without notice.

CONSTRUCTION:

6 mm heavy duty steel firebox – fully welded
25mm thick firebrick lined floor, back and sides
19mm ceramic baffle plates

NOTE:

The floor protector consists of an 80mm thick Bellis Board or similar material which has a thermal resistance of 0.1m² k/W, under the unit.

18mm thick board can be used in front of unit.

New flue kit active + half heatshield – “Any single heatshield can be used from 900mm up to 1200mm height”

“This heater has been tested with the fan connected to a standard 3 pin GPO socket outlet. The fan does not need to be hard wired”.

PERFORMANCE:

Heating capacity – 220-320m² (23-33 squares)
Average peak heat output – 6.7kW
Average Particulate emission - 1.5g/kg
Average efficiency – 68%

Heating capacity of this appliance is given as a guide only and may vary depending on the climate zone and type of dwelling (floor plan and degree of insulation). Consult your local authorised distributor to determine realistic expectations for your home.

Heat output and fuel consumption of this appliance is dependent on the moisture content, size, loading geometry and the type of softwood used.

The appliance complies to the safety standards AS/NZS 2918. When in use some parts may become hot. A suitable fireguard is recommended where the very young, elderly or infirm are concerned.

HEARTH MEASUREMENT

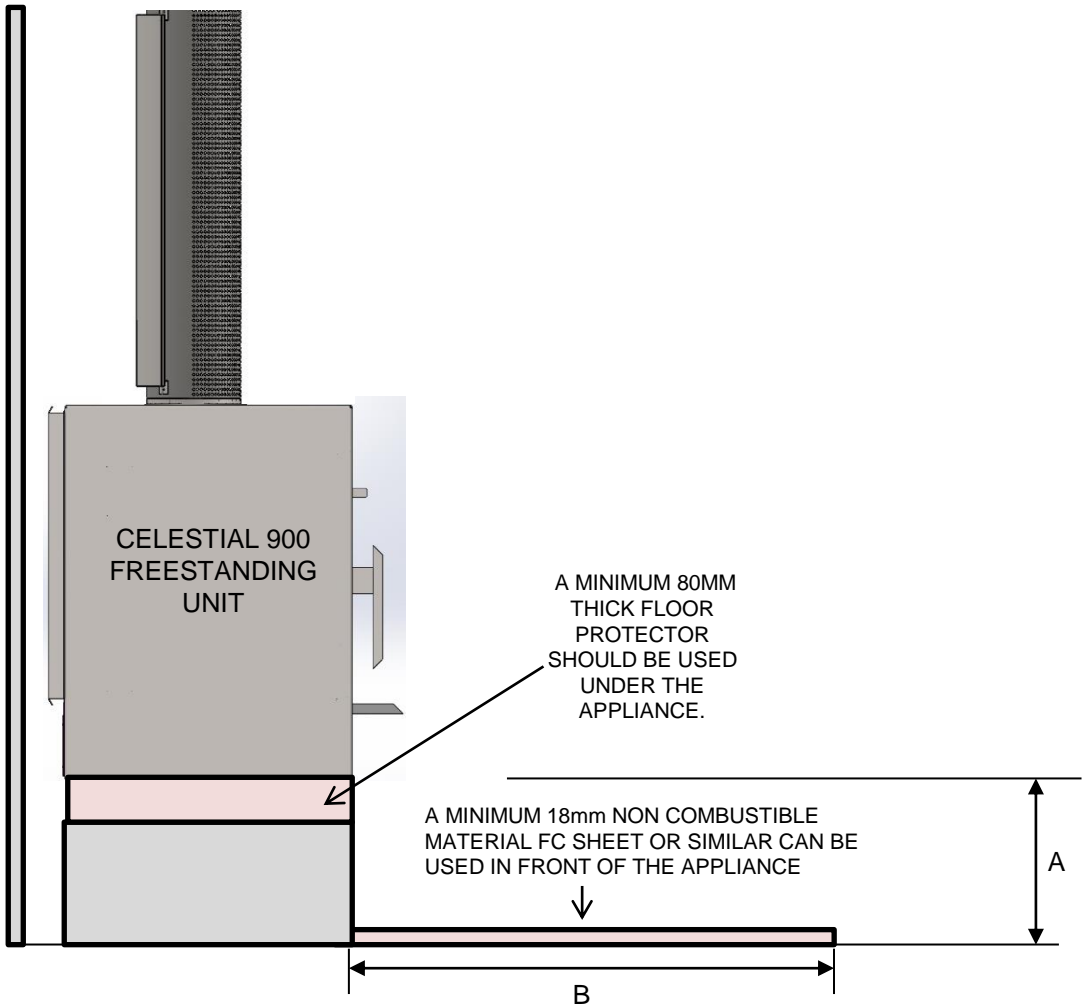

A.	UNIT HEIGHT ABOVE FLOOR	200
B.	HEARTH DIMENSION FORWARD OF UNIT	460

HEARTH REQUIREMENTS FOR INSTALLATION ONTO A RAISED HEARTH

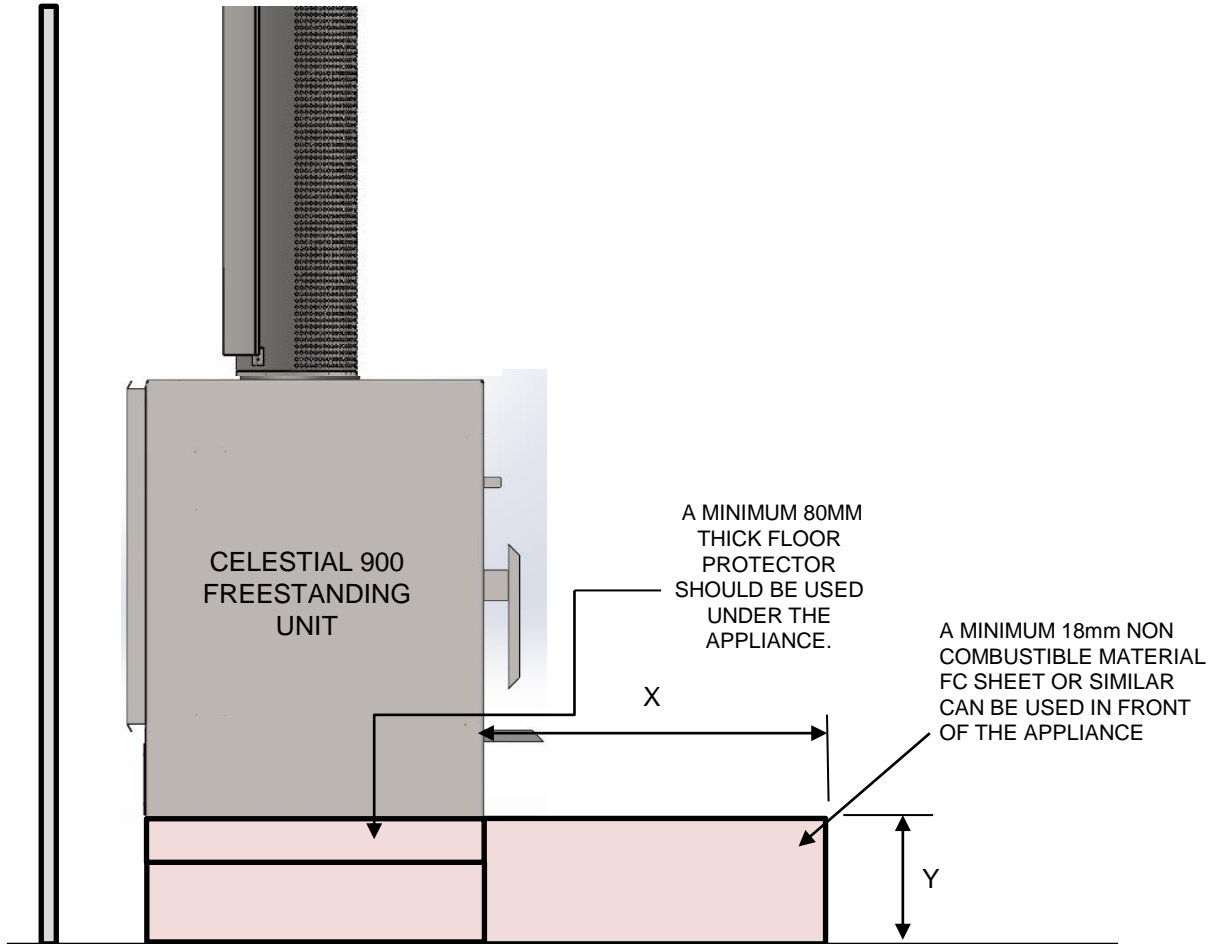

X.	MIN. DEPTH MEASUREMENT (mm)	300
Y.	MIN. HEIGHT INCREASE (mm)	200*

* NOTE: IF Y IS LESS THAN 200mm THEN REFER TO HEARTH MEASUREMENT ON PREVIOUS PAGE

**MINIMUM REQUIREMENTS FOR
INSTALLATION ON A STEEL TABLE**

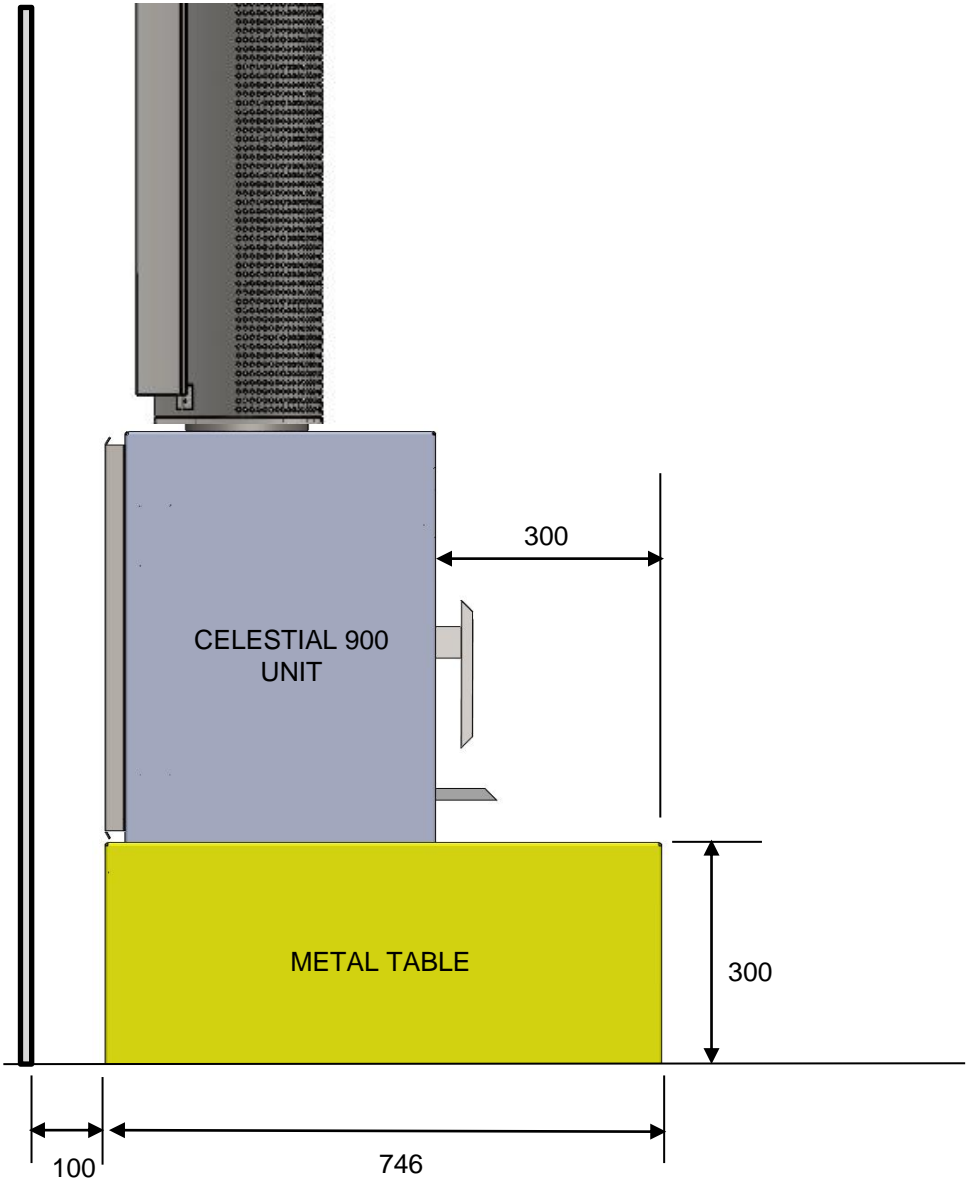

* NOTE: NO FC SHEETING UNDER THE APPLIANCE IS REQUIRED FOR THIS ASSEMBLY.

BAFFLE PLATE INSTALLATION

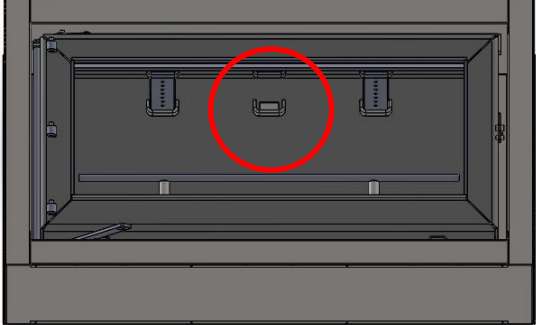

1. REMOVE MIDDLE AIR TUBE BY PUSHING UP AND REMOVING FROM FRONT AND REAR BRACKETS.

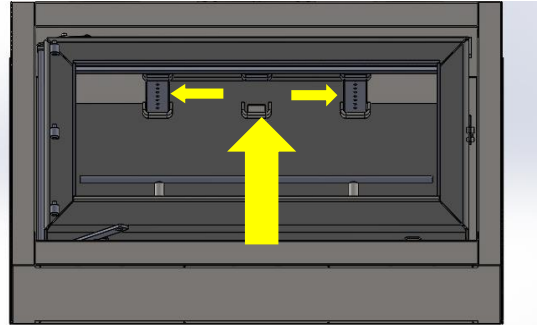

2. PLACE ALL 4 BAFFLE PLATES ABOVE AIR TUBES BOTH SIDES CLOSEST TO THE FIRE BOX WALL AS SHOWN (2 LEFT AND 2 RIGHT)

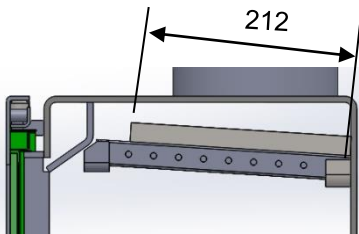

3. PLACE BAFFLE PLATES AS FAR BACK AS POSSIBLE, 222 MM FROM FRONT TO BACK.



4. BAFFLE PLATE SIDE OF 212 MM SHOULD EXTEND FROM SIDE TO SIDE,

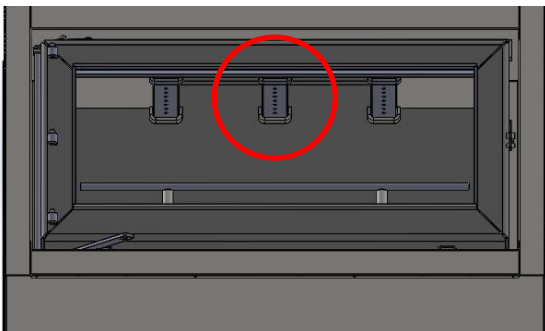

5. RE- PLACE MIDDLE AIR TUBE BACK INTO POSITION
(NB. MAKE SURE OPEN END OF AIR TUBE IS PLACED INTO REAR OPENING. CLOSED END TOWARDS DOOR. FAILURE TO INSTALL AIR TUBES CORRECTLY WILL VOID WARRANTY.)

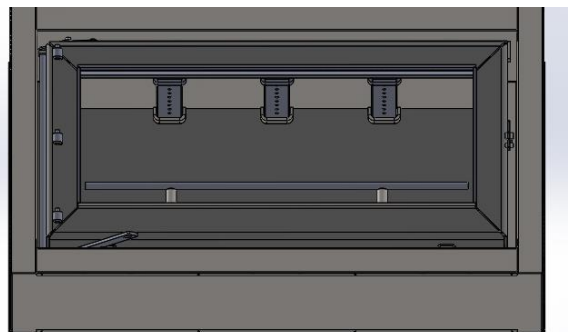

6. SLIDE THE BAFFLE PLATES ATOP THE OTHER 2 BAFFLE PLATES INTO THE MIDDLE POSITION AS SHOWN. LEAVE GAP OF 1-2 MM IN BETWEEN PLATES. THE GAPS SHOULD BE ROUGHLY IN THE MIDDLE OF THE AIR TUBES. UNIT IS NOW READY FOR USE.

CELESTIAL 900 DOOR ADJUSTMENT INFORMATION

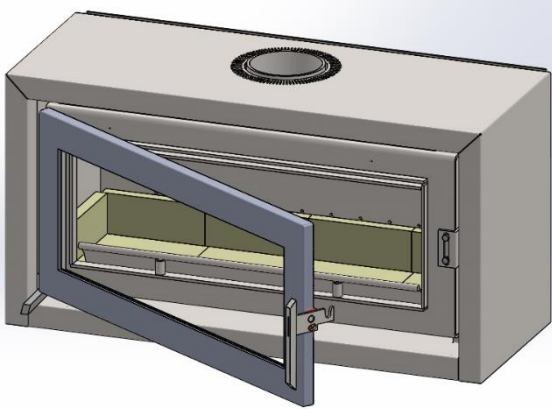

1. OPEN THE DOOR AS FAR AS REQUIRED, AND THE ADJUSTMENT ANGLE IS ACCESSIBLE.

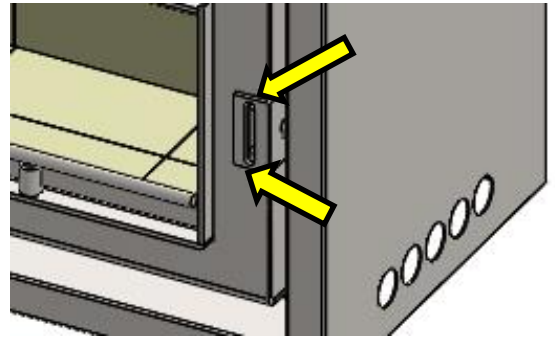

2. MARK THE POSITION OF THE ADJUSTMENT ANGLE ON THE FIREBOX. IT IS CRITICAL TO PUT THE ADJUSTMENT ANGLE AT THE SAME SPOT. SO THAT THE DOOR WILL LOCK PROPERLY.

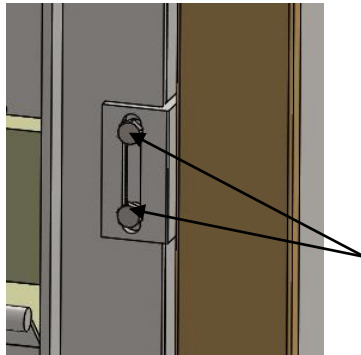

3. LOOSEN THE 2 BOLTS AS REQUIRED. DO NOT UNSCREW THE BOLTS ALL THE WAY OUT.

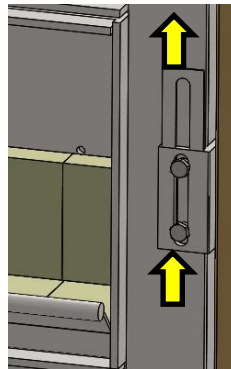

4. PUSH THE PACKER FROM THE BOTTOM EDGE OF THE ADJUSTMENT ANGLE UNTIL FULLY REMOVED. ONLY TAKE OUT WHAT IS NECESSARY. RE-POSITION THE ADJUSTMENT ANGLE AT THE MARKERS AND TIGHTEN. NOTE: UP TO 4 PACKERS CAN BE REMOVED IF NECESSARY.

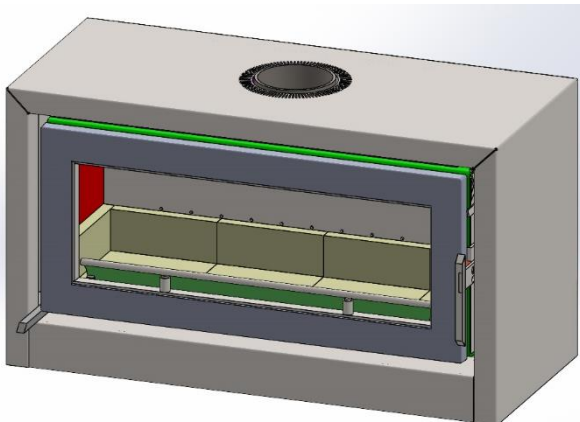

5. CLOSE THE DOOR AND CHECK IF THE LATCH LOCKS PROPERLY, THE ADJUSTMENT IS COMPLETE IF NO ADJUSTMENT IS NEEDED.

SEISMIC RESTRAINTS MERIDIAN BASE INSTALLATION

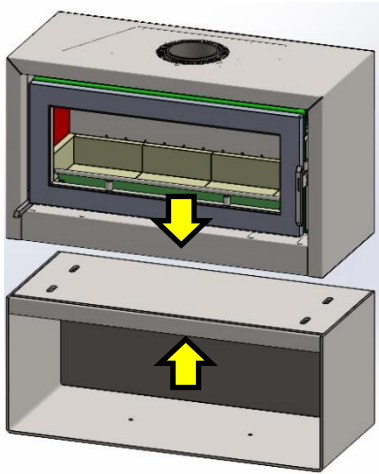

Place the appliance on top of the meridian base. Make sure to align the front and side edges of the appliance to the meridian base.

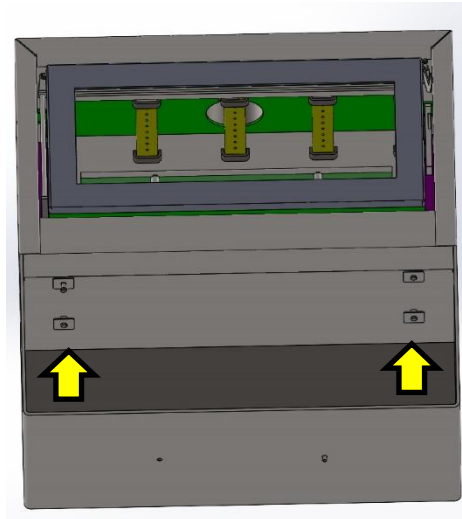

Locate and align the holes on the underside of the appliance and top of the meridian base. Use the supplied bolts and washers, then tighten, this will hold the appliance in place.

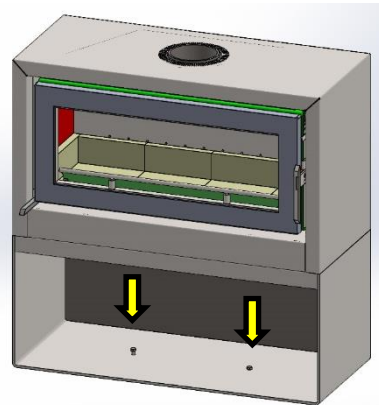

Position the appliance and meridian base assembly to the desired position. Make sure the flue hole is in the required position. Use the existing holes at the bottom of the meridian base to drill the holes for m8-m10 dyna bolts. Use the preferred dyna bolt size and affix the appliance and meridian base assembly to the floor. When both dyna bolts are tightened the installation is complete.

SEISMIC RESTRAINTS TABLE INSTALLATION

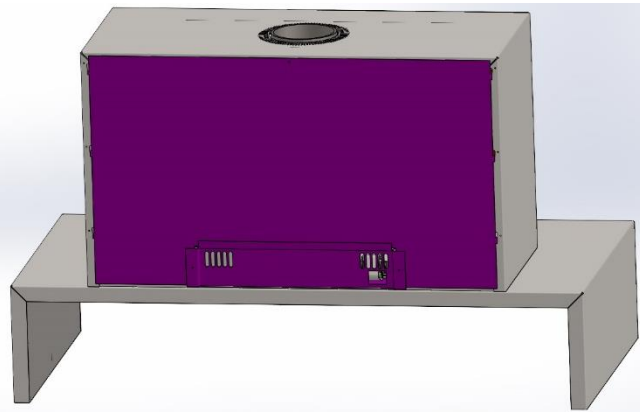

Place the back of the appliance aligned to the back edge of the cube table. Make sure the appliance is centred from the left and right edges.

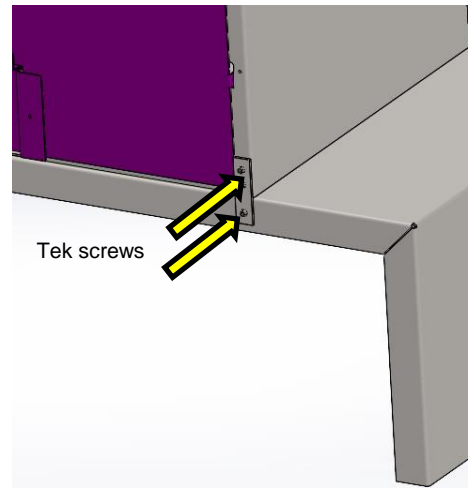

Attach the supplied bracket by locating the holes in the appliance and table on both sides as indicated. Use Tek screws and attach the appliance by using the pilot holes on the bracket. Position bracket to 10mm from the underside of the table and edge of the appliance on the side.

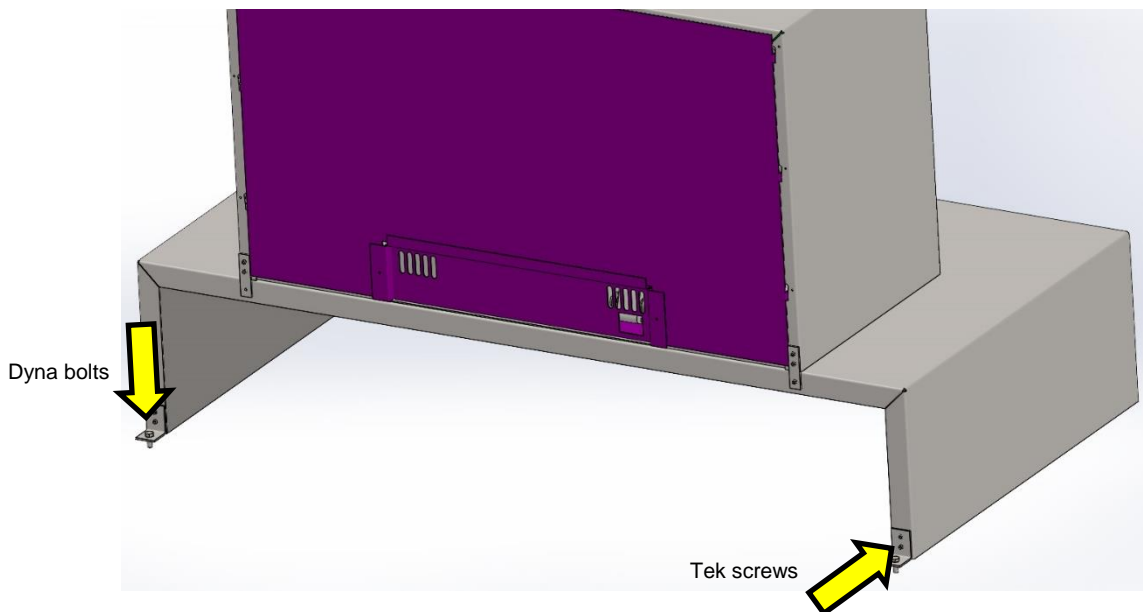

Position the appliance and table assembly to the desired position. Make sure the flue hole is in the correct position. Use Tek screws and attach the bracket to the table. Use the holes at the bottom of the angle bracket to drill the holes for m8-m10 dyna bolts to the floor. Use the preferred dyna bolt size and affix the appliance and table assembly to the floor. When both dyna bolts are tightened the installation is complete.

FREESTANDING UNIT WITH HEAT SHIELD

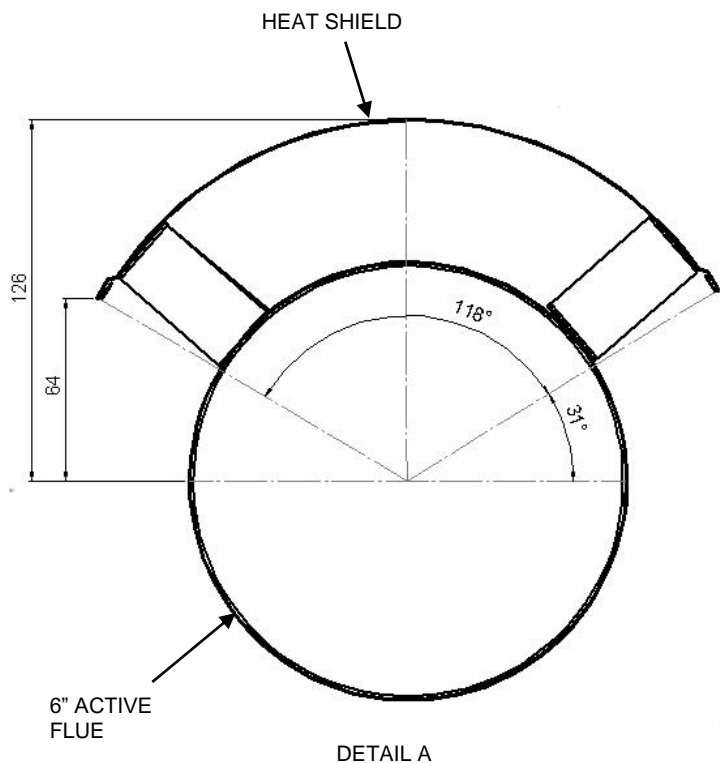

DETAIL A

THE HEAT SHIELD WILL COVER 33% OF THE TOTAL CIRCUMFERENCE OF THE ACTIVE FLUE.

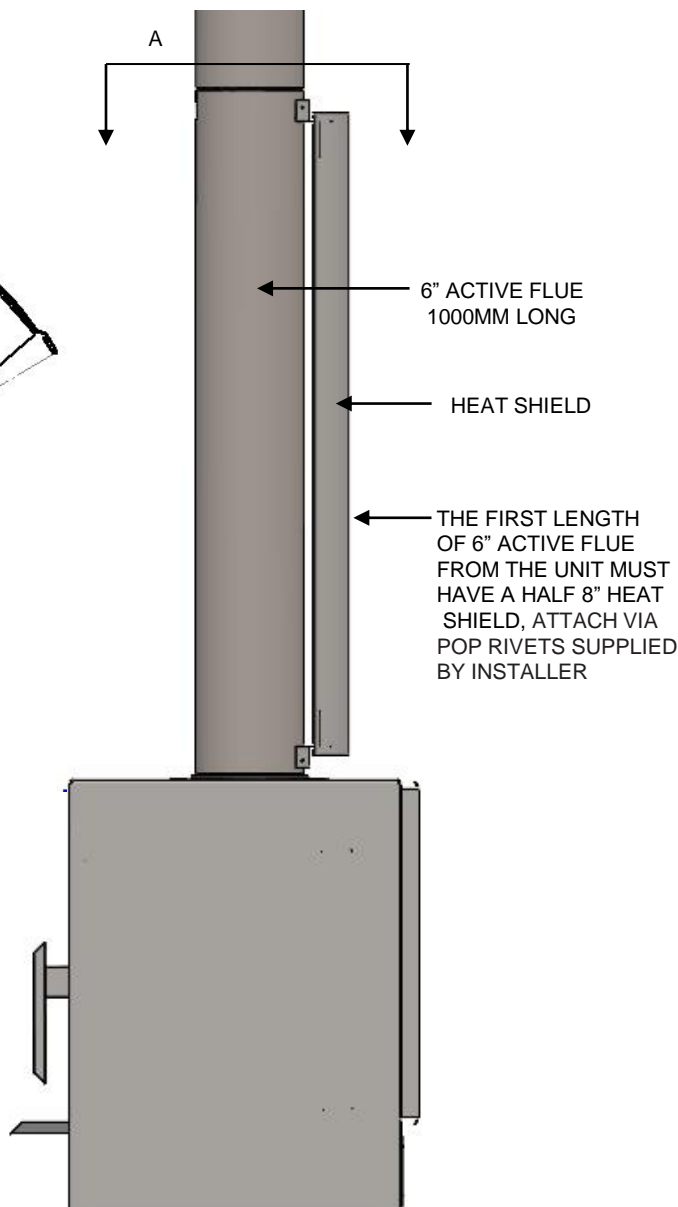

IMPORTANT:

NEW FLUE KIT ACTIVE + HALF HEATSHIELD – “ANY SINGLE HEATSHIELD CAN BE USED FROM 900MM UP TO 1200MM HEIGHT”

“THIS HEATER HAS BEEN TESTED WITH THE FAN CONNECTED TO A STANDARD 3 PIN GPO SOCKET OUTLET. THE FAN DOES NOT NEED TO BE HARD WIRED”.

SINGLE HEATSHIELD INSTALLATION INFORMATION FOR FLAT CEILING

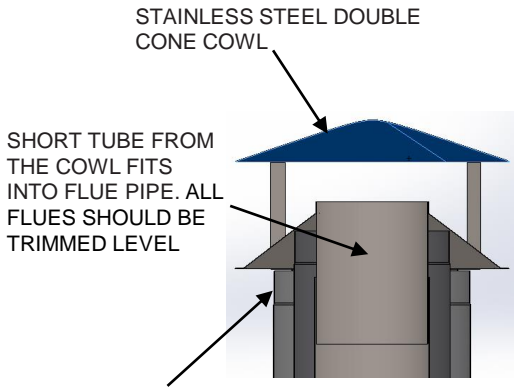

POP RIVET OR SCREW BRACKETS TO THE OUTSIDE OF THE OUTER CASING

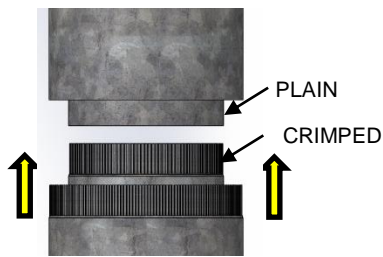

ALL 8"-10" ASSEMBLED FLUES MUST HAVE THE CRIMPS POINTING UPWARDS

DETAIL B

DETAIL A

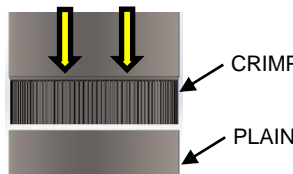

ALL 6" ASSEMBLED FLUES MUST HAVE THE CRIMPS POINTING DOWNWARDS

DETAIL D

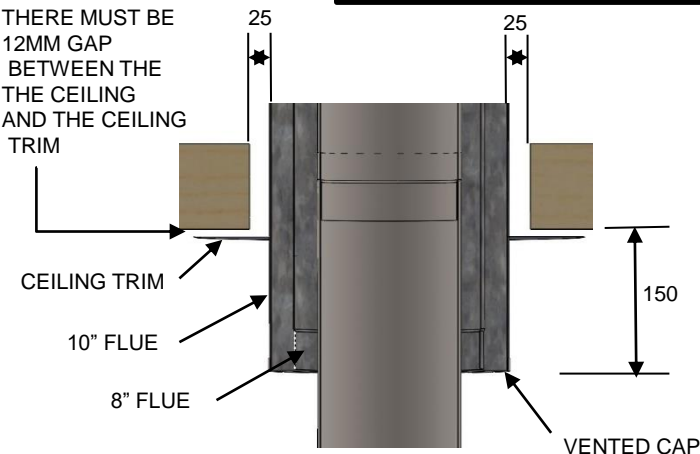

DETAIL C

RUN A BEAD OF SILICONE DOWN THE VERTICAL SEAM OF THE OUTER CASING TO THE FLASHING

ROOF FLASHING SUPPLIED BY CONTRACTOR

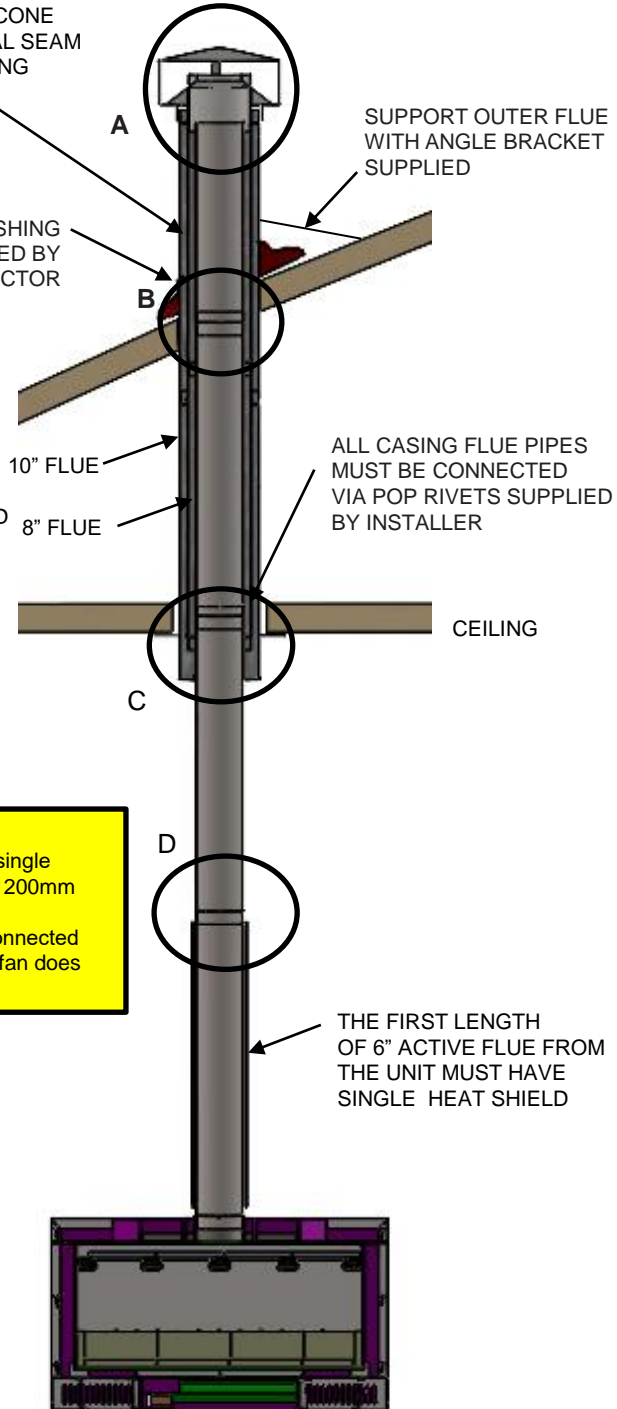

IMPORTANT:
New flue kit active + half heatshield – "Any single heatshield can be used from 900mm up to 1200mm height"
"This heater has been tested with the fan connected to a standard 3 pin GPO socket outlet. The fan does not need to be hard wired".

SINGLE HEATSHIELD INSTALLATION INFORMATION FOR RAKED CEILING

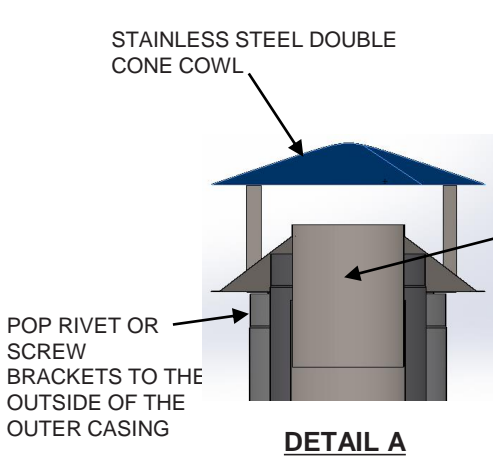

RUN A BEAD OF SILICONE DOWN THE VERTICAL SEAM OF THE OUTER CASING TO THE FLASHING

SHORT TUBE FROM THE COWL FITS INTO FLUE PIPE. ALL FLUES SHOULD BE TRIMMED LEVEL

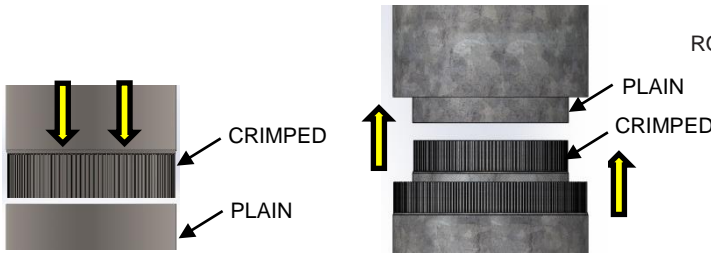
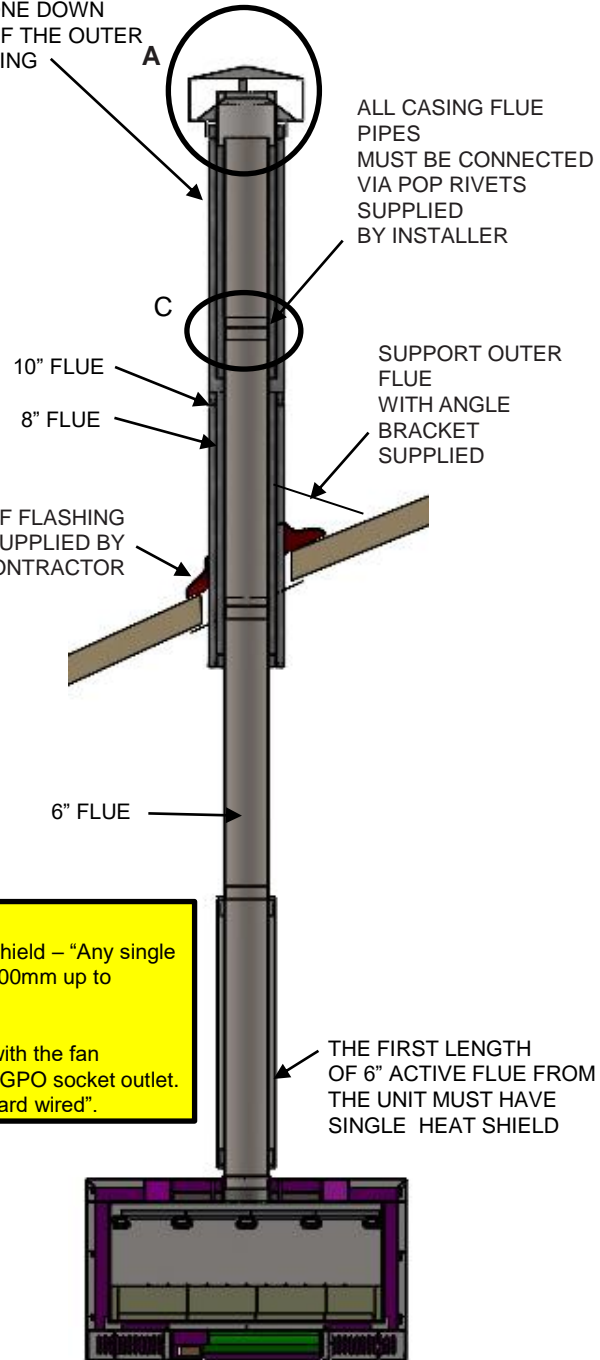

ALL 6" ASSEMBLED FLUES MUST HAVE THE CRIMPS POINTING DOWNWARDS

ALL 8"-10" ASSEMBLED FLUES MUST HAVE THE CRIMPS POINTING UPWARDS

DETAIL D

DETAIL C

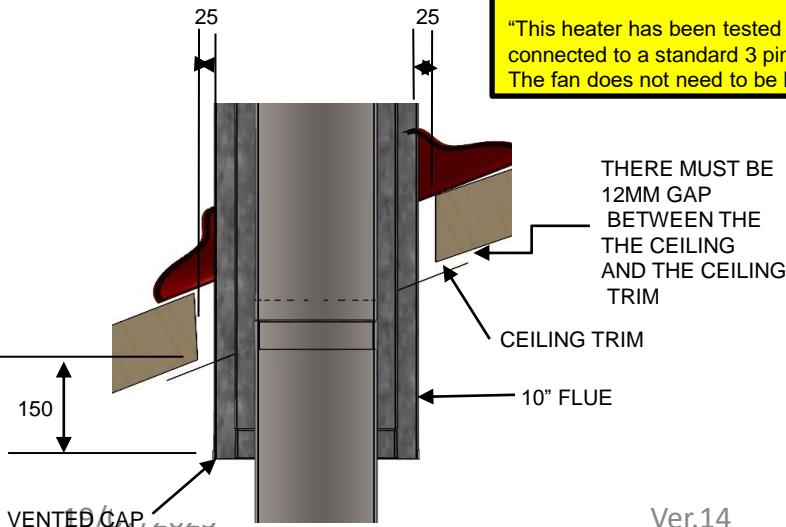

CELESTIAL 900 FREESTANDING INFORMATION FOR DECRO INSTALLATION

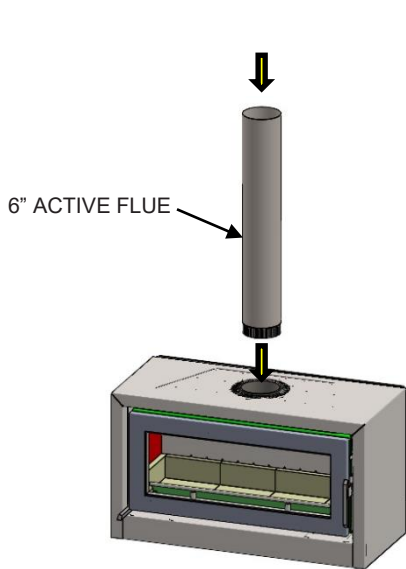

6" ACTIVE FLUE

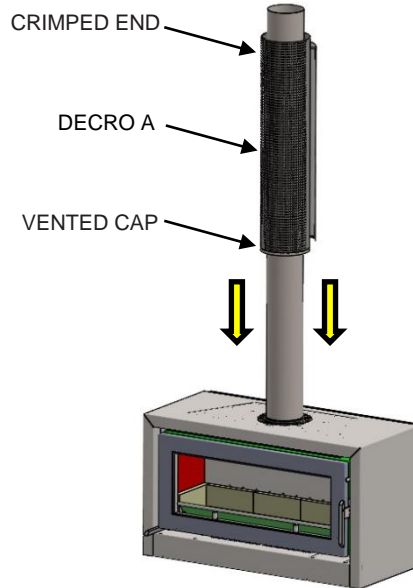

CRIMPED END

DECRO A

VENTED CAP

INSTALL THE FIRST 2 LENGTHS OF 6" ACTIVE FLUE. ALL 6" ASSEMBLED FLUES MUST HAVE THE CRIMPS POINTING DOWNWARDS. CONNECT THE FLUE WITH POP RIVETS, SUPPLIED BY INSTALLER.

INSTALL THE FIRST LENGTH OF DECRO (DECRO A) USE THE DECRO FLUE WITH THE VENTED CAP CLOSEST TO THE TOP OF THE APPLIANCE.

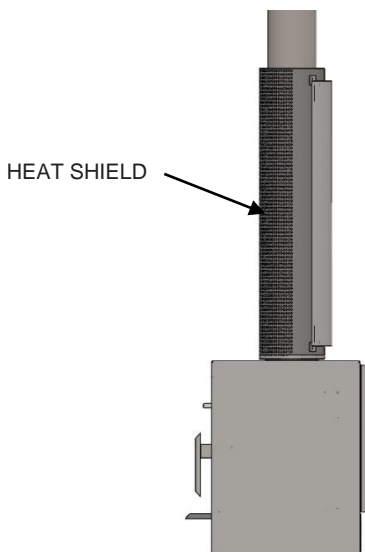

HEAT SHIELD

IMPORTANT: ANY APPENDIX F APPROVED FLUE KITS CAN BE USED ON THESE KEMLAN FREESTANDING FIREPLACES AS LONG AS IT COMPLIES WITH THE LABORATORY TESTED HEAT SHIELDING"

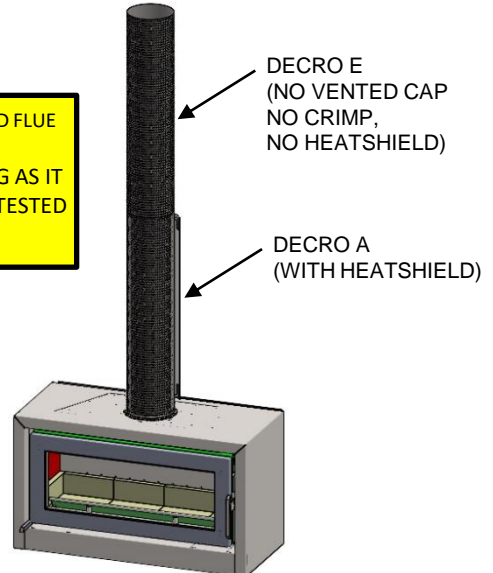

DECRO E
(NO VENTED CAP
NO CRIMP,
NO HEATSHIELD)

DECRO A
(WITH HEATSHIELD)

MAKE SURE THE HEATSHIELD IS POSITIONED ADJACENT TO THE REAR WALL..

INSTALL THE NEXT LENGTH OF DECRO. A VENTED CAP IS ALSO SUPPLIED LOOSE TO BE USED AS REQUIRED. CONNECT WITH POP RIVETS SUPPLIED BY INSTALLER

CELESTIAL 900 FREESTANDING INFORMATION FOR FLAT CEILING

STAINLESS STEEL DOUBLE
CONE COWL

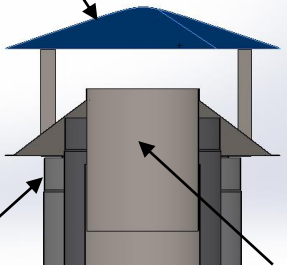

POP RIVET OR SCREW
BRACKETS TO THE
OUTSIDE OF THE
OUTER CASING

DETAIL A

RUN A BEAD OF SILICONE DOWN
THE VERTICAL SEAM OF THE OUTER
CASING TO THE FLASHING

ROOF FLASHING
SUPPLIED BY
CONTRACTOR

SHORT TUBE FROM
THE COWL FITS
INTO FLUE PIPE. ALL
FLUES SHOULD BE
TRIMMED LEVEL

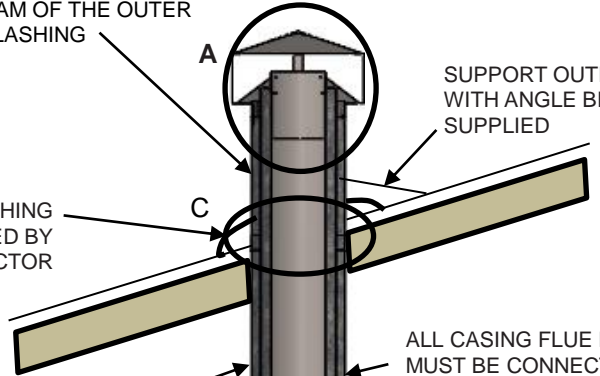

SUPPORT OUTER FLUE
WITH ANGLE BRACKET
SUPPLIED

ALL CASING FLUE PIPES
MUST BE CONNECTED
VIA POP RIVETS SUPPLIED
BY INSTALLER

10" FLUE

8" FLUE

B

CEILING

6" FLUE

8" DECRO

D

STAINLESS STEEL
FLUE PIPE. ALL FLUE
PIPES MUST BE
CONNECTED WITH
POP RIVETS
SUPPLIED BY
INSTALLER

**IMPORTANT: ANY APPENDIX F
APPROVED FLUE KITS CAN BE
USED ON THESE KEMLAN
FREESTANDING FIREPLACES
AS LONG AS IT COMPLIES
WITH THE LABORATORY
TESTED HEAT SHIELDING"**

THE FIRST LENGTH
OF 8" DECRO FROM
THE UNIT MUST HAVE
DOUBLE HEAT SHIELD
(refer page 2 for clarification)



ALL 6" ASSEMBLED FLUES
MUST HAVE THE CRIMPS
POINTING DOWNWARDS

DETAIL D

ALL 8"-10" ASSEMBLED FLUES
MUST HAVE THE CRIMPS
POINTING UPWARDS

DETAIL C

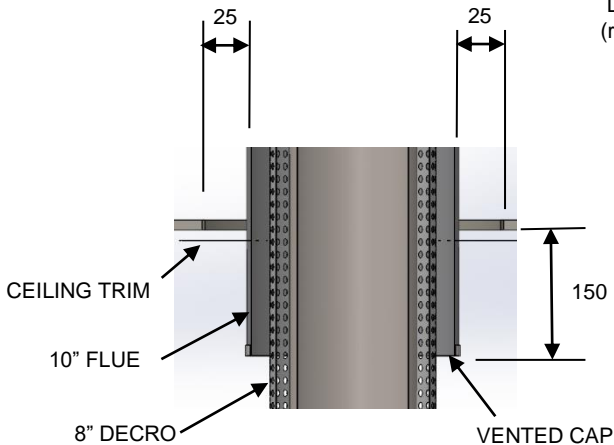

DETAIL B

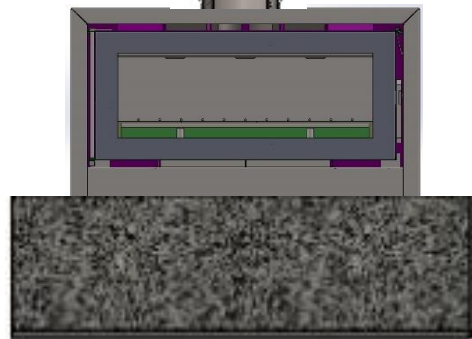

FRONT VIEW

CELESTIAL 900 FREESTANDING INFORMATION FOR RAKED CEILING

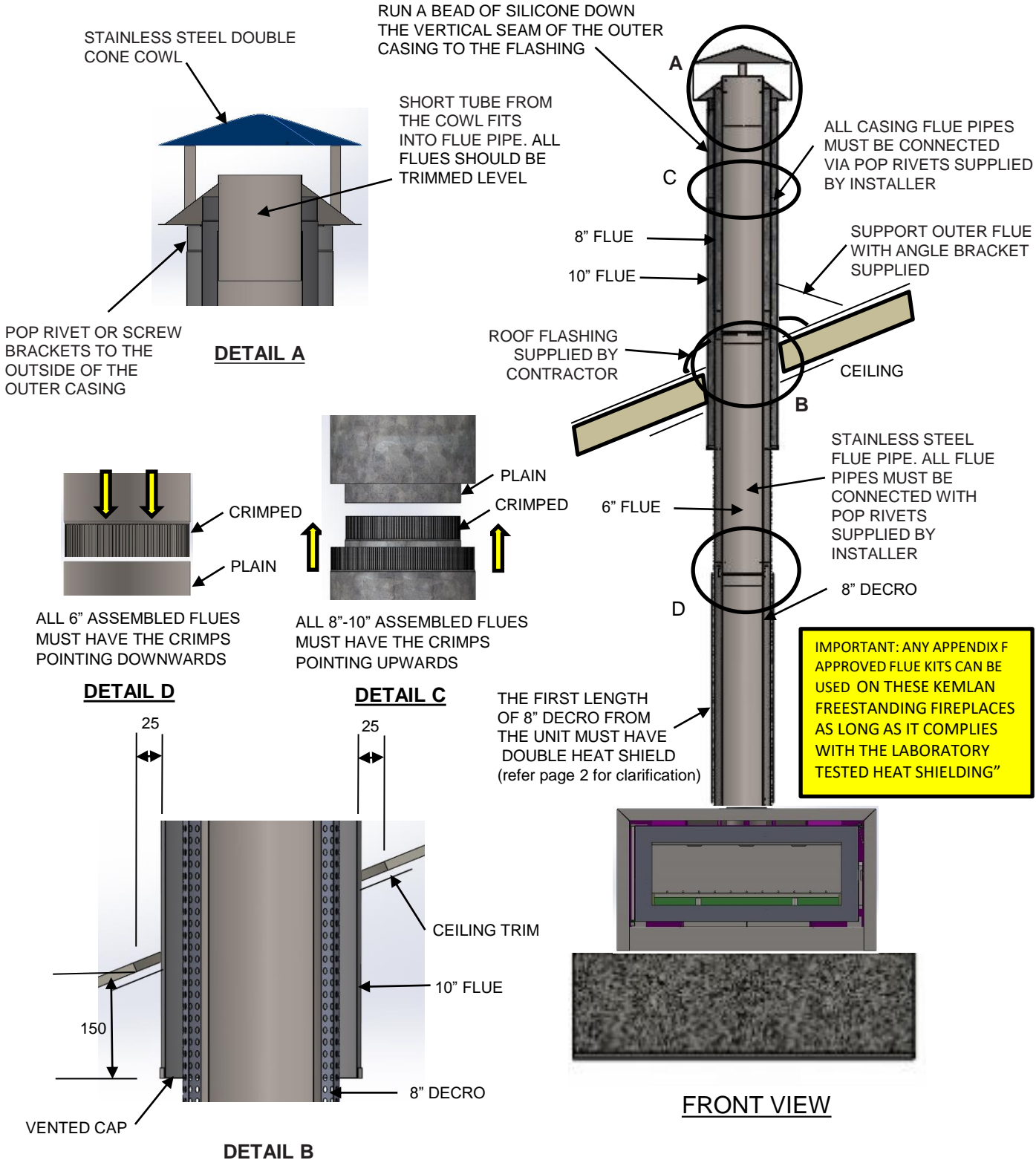

CELESTIAL 900 BOOST OPERATION

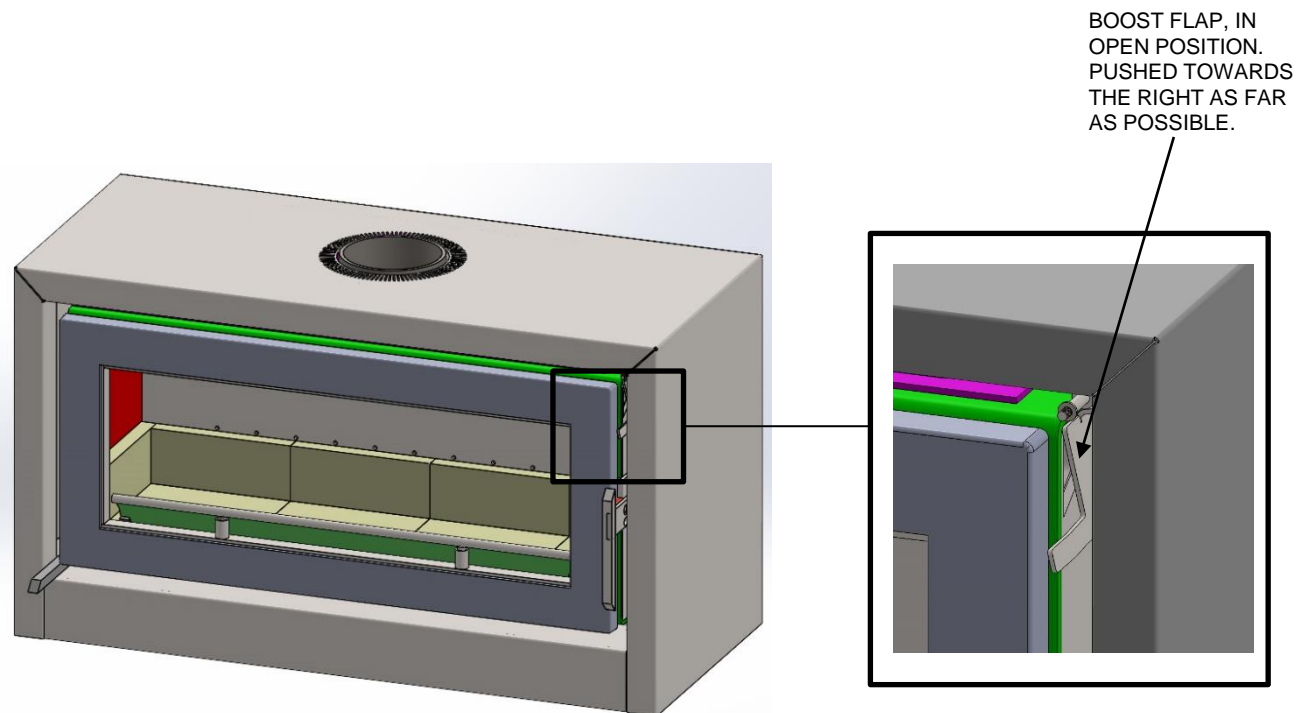

NOTE:

The boost flap need to be left open for the **first 20 minutes** of operation, in order to light the fire better. After this time, normal appliance operation will commence and the boost flap will need to be shut for the duration of use.

INSTALLATION INSTRUCTIONS

MINIMUM HEIGHT OF FLUE SYSTEM EXIT INSTALLATION TO COMPLY WITH AS/NZS 2918

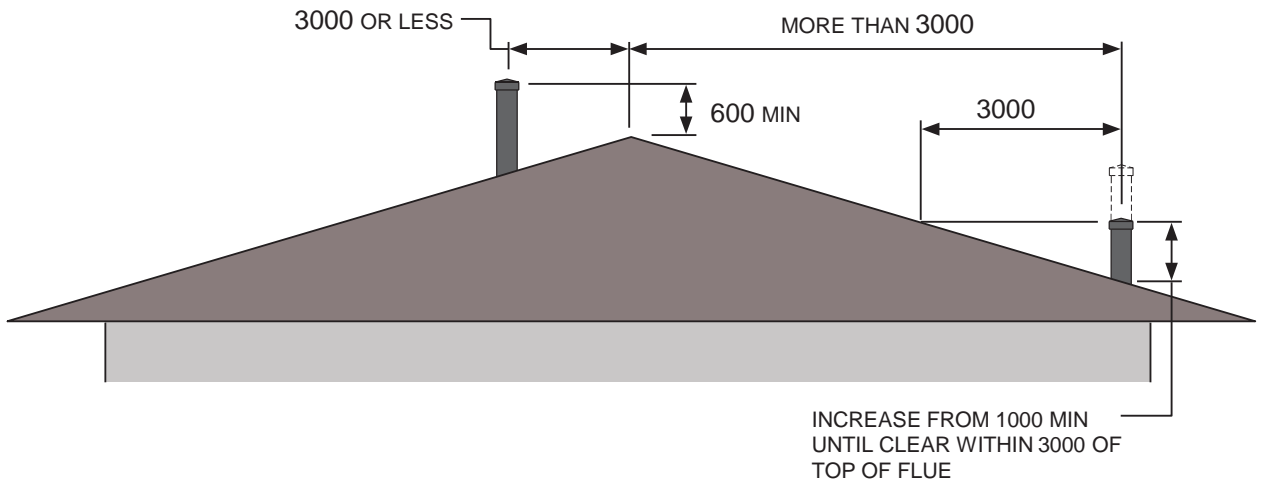
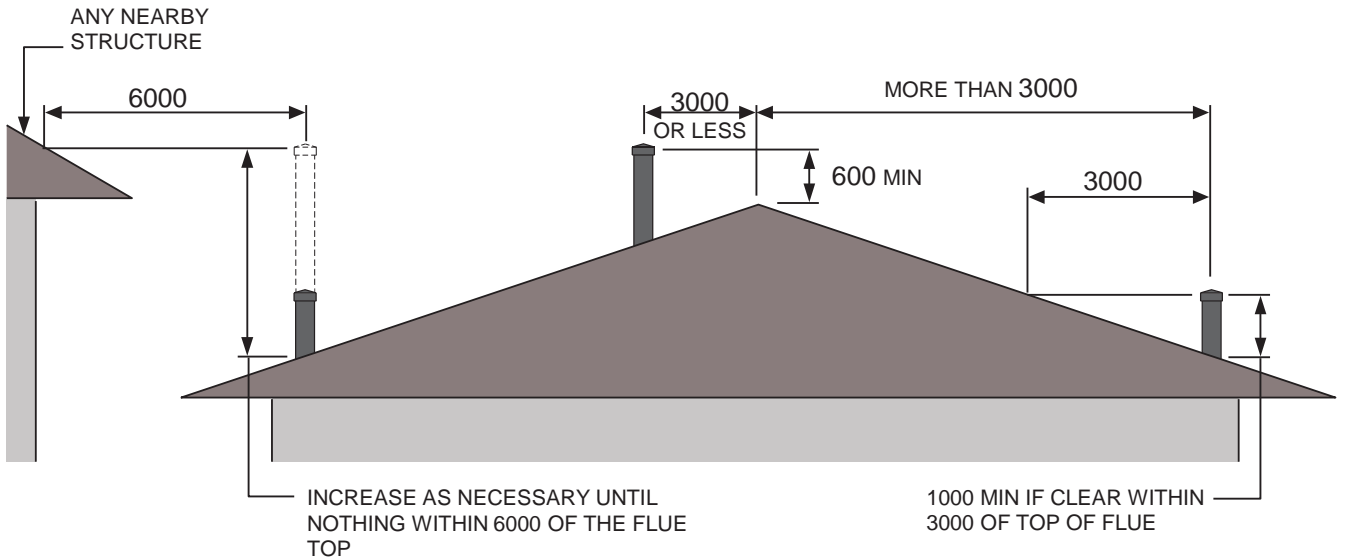

DIMENSIONS IN MILLIMETRES



Certificate of Compliance for **SOLID FUEL HEATERS**

This is to certify that the appliance stated on this certificate has been tested for Thermal Clearances, Heat Output, Thermal Efficiency and Particulate Emissions in accordance with the Australian / New Zealand Standard(s) detailed below

<i>Manufacturer</i>	Kemlan Industries
<i>Make</i>	Kemlan
<i>Model</i>	Celestial 900
<i>Type</i>	Free-Standing
<i>Category</i>	Slow combustion Wood Heater
<i>Fuel Type</i>	Softwood
<i>Test Report No:</i>	ASFT20012-1 HCMG/15/060
<i>Maximum Avg Heat Output</i>	6.7kW
<i>Overall Avg Efficiency</i>	68%
<i>Particulate Emissions Factor</i>	1.5g/kg
<i>National Standards</i>	AS/NZS 4012 (2014) AS/NZS 4013 (2014) AS/NZS 2918 (2018)

ASFT hereby grants to:

Kemlan Industries

of

13 French Avenue, Brendale QLD, Australia, 4500

Certificate No.: **ASFT20C039**

Certified Date: **10 July 2020**

Issue Date: **10 July 2020**

Expiry Date: **8 August 2024**

Steve Marland

Managing Director of ASFT

ASFT is an accredited laboratory by the National Association of Testing Authorities (NATA accreditation No. 20042) for compliance with ISO/IEC 17025. ASFT performs compliance testing of Solid Fuel Appliances to the relevant Australian/New Zealand standards under this Accreditation. This activity is coupled with periodic surveillance of the certified product taken from the market place or the manufacturer's factory. This certification is subject to the conditions set forth in the characteristics below and is not to be construed as any recommendation, assurance or guarantee by ASFT of the product acceptance by Authorities having jurisdiction.

Australian Solid Fuel Testing, 3 Garden Street, Morwell, Victoria, Australia 3840
ABN 46 610 154 768

KEMLAN INDUSTRIES

Operating Instructions

Congratulations on the purchase of your Australian made Kemlan slow combustion wood fireplace.

We hope this serves you well, not just as a stunning feature; but as a functional tool for heating your home and keeping you and your family warm however cold the winters may get, because this is what Kemlan specialises in and has perfected, making fires in Brisbane QLD since 1969, 'Australian made for Australian conditions'.

Welcome to the Kemlan family.

I would like to share with you the correct way to operate your Kemlan wood fire giving best results for both heating and useability.

Let's get started:

The First Burns –

Unfortunately, we have no control over how the fire is loaded nor do we have any control over what quality of fuel / timber is used, therefore we can only give recommendations, and this will be the difference in heat output and length of burn.

Hard wood should always be used as the main fuel source in all Kemlan wood heaters at a moisture level of between 12% - 20% (always have a moisture meter).

If the timber is too dry it will burn faster, if the timber is too wet it will struggle to burn at all and give very little heat.

The first few burns in a wood fire are commonly referred to as 'curing burns', this is when you are getting heat into the appliances steel and paint for the first time.

What we are trying to achieve here is 3-fold:

The **first** goal is to get heat into the white ceramic baffles and the steel flue system, getting these 2 things hot will create the 'draw' of the fireplace this is the process in which the smoke is drawn out of the fireplace chamber through the flue system.

The **second** goal is to lay a bed of ash in the base of the fire, ash in the bottom of the fire is essential to the performance of the fireplace, the optimal thickness of ash is 2-3 Inches (25mm - 75mm).

Having this bed of ash will assist the fuel to light easier creating an air layer under the timber, it will also assist in a longer hotter burn as the ash holds a large amount of the heat while the timber above is burning. So DO NOT clean your ash out until you have to, you should never see the firebricks in the base of your fire.

The **third** goal of the initial burns is to cure the paint on the fireplace casing, Kemlan fires are painted with a high temperature paint. When first applied at our factory, the paint is very soft, we place all finished fireplaces under heat lamps to start the 'curing' process but because of the time it takes and

the temperature the casing needs to stay at to complete this process we need YOU to finish this cure in your home by lighting your new fire! So, let's do it!.....

Building your fire -

Whether you have purchased a small, medium or large chamber fireplace the set-up is the same.

Kemlan introduce more primary air into the chamber of the fireplace than most other brands on the market, this makes it very easy to light the fire from a cold start, it also makes it easy for you the user of the fireplace to load the paper or firelighters, kindling (small pieces of soft wood) and hard wood into the chamber straight away.

Your goal should be to fill the fireplace chamber front to back, sided to side to make sure heat is evenly distributed throughout the entire firebox.

We don't want to have to keep tending to the fireplace slowly adding pieces of timber and constantly opening the door, one full load of timber is far better.

Scan the QR code below to access the 'How to stack and light your Kemlan wood fire' video.

Please take some time to watch to see if your process is the same.



Now your Kemlan fire is up and running make sure to keep the primary air slide fully open, this will ensure maximum oxygen is getting to the fuel and this will create quicker heat into the fireplace box, baffle, flue and of course your home.

The air slide can move from extreme left (fully open) to extreme right (fully closed).

Think of this slide like an accelerator and brake on a car. Fully open would be putting your foot down on your car's accelerator, fully closed is like putting the breaks on in the car.

When we want energy into the room (KW) we want the slide open, as the room gets to the desired temperature the air slide can be moved towards the right-hand side reducing the air to the chamber slowing the energy output and fuel consumption.

The air slide should only be moved half to $\frac{3}{4}$ of the way across while you can still tend to the fire, closing it completely or starving the fire should only be done when you cannot tend to the fire for long periods of time (e.g. going to bed) when your only goal is for length of burn.

Remember no matter whether it is a curing burn or an everyday use, heat is key, never light a small fire! A small fire in a large, chambered firebox will not produce any heat in the components of the fireplace or in your room. Choose the fire that best suits your living and heating requirements.

Reloading your Kemlan fire –

When it is time to add timber to your fireplace firstly make sure the underside of your white baffles is actually white, if they are still black this will mean the hardwood has not fully caught alight. If this is the case wait, you will notice as the fire heats up and your seasoned hardwood is fully lit the baffle plates will return to their original white condition, this means the fire drawing correctly through the flue system and burning cleanly with the secondary air in full swing.

You can now open the air slide fully, crack the door slightly allowing the air pressure to equal then carefully fully open the door.

Have the timber you are going to load in the chamber ready to immediately reload, be prepared, don't open the door and then go looking for the optimal pieces of timber, the longer you wait the colder the chamber will get and the higher the chance of smoke coming back into the room.

Overnight burns –

All medium and large size Kemlan fireplaces have what is called an 'overnight burn' but what does this mean??

Like we have touched on above, the air slide should only be shut down fully when you want extended length of burn, as soon as you starve the firebox of air the fire will burn dirtier and heat output will be greatly reduced, in some instances the glass will blacken due to the lack of air movement inside the chamber. The black creosote will burn off the glass when the fire's air control is back up to high with a new load of timber.

Generally, a Kemlan medium to large chamber will burn between 8 – 12 hours depending on the quality of fuel/timber and how full you stack the chamber. For maximum burn time you would fill the chamber up to 50mm below the secondary air tubes underneath the white baffle plate. The larger the pieces of timber the better!

After the 8-12 hours you should still have glowing embers in the base of the fire, a small amount of kindling and medium size pieces of hardwood can then be re-loaded making sure the air control has been moved back to 'full left' introducing maximum primary air again.

If you follow these simple steps, you will find your Kemlan fireplace is one of the best investments you have made to your home.

From everyone in Kemlan we thank you for your business and wish you a lifetime of warmth and enjoyment.

IMPORTANT:

UNDER NO CIRCUMSTANCES SHOULD ANY SOLVENTS SUCH AS METHYLATED SPIRITS, PETROL, MINERAL TURPENTINE ETC OR DETERGENTS, BE ALLOWED TO COME IN CONTACT WITH THE PAINTED SURFACE OF THE HEATER AS DAMAGE TO THE FINISH WILL RESULT. IF AN ACCIDENT DOES OCCUR, SPRAY CAN PAINT IS AVAILABLE FROM YOUR NEAREST KEMLAN DEALER.

WARRANTY

1. Kemlan wood heaters carry a warranty on the 6mm firebox for a period of ten (10) years.
2. This warranty also covers other components of the heater for a period of one (1) year. These components include the baffle plate, handle assembly, secondary air tubes and fan.
3. Kemlan's warranty covers the wood heaters against defects in materials and manufacture.

4. THIS WARRANTY DOES NOT COVER –

- 4.1 Failure to comply with manufacturer's operation instructions.
- 4.2 Normal wear and tear or damage caused by incorrect installation.
- 4.3 Any form of rust and/or corrosion to the painted finish of the heater.
- 4.4 Damage to the glass in the door, if the damage is caused by impact or misuse.
- 4.5 The cost of collection and delivery of the wood heater and/or parts.
- 4.6 Damage caused by water ingress.
- 4.7 Cost of removal of defective heater or re-installation of replacement heater.
- 4.8 Failure to use fireplace components supplied by Kemlan Industries Pty Ltd.
- 4.9 Cost of inspection for damaged heater.

5. CLAIMS –

- 5.1 (i) Kemlan will provide a full replacement of the heater in the first five years after installation.

(ii) Replacement in the subsequent five years (i.e. sixth to tenth year after installation will be on the following basis.
Owner will pay fifty percent of the current retail price, if the claim is made in the sixth year – tenth year after purchase.
- 5.2 Replacement of heater subject to all conditions in section four of warranty.
- 5.3 Should any defects occur, contact the Kemlan distributor from whom you purchased the heater.
- 5.4 Under this warranty the defective parts will be repaired or replaced, free of charge.
6. The fireplace installation must comply with the relevant local statutes, ordinances, regulations and by-laws.

7. THIS WARRANTY IS VOID IF:

- 7.1 The appliance has been over-fired or operated in atmospheres contaminated by chlorine, fluorine or other damaging chemicals. Over-firing can be identified by, but not limited to, warped plated or tubes, rust coloured cast iron, bubbling, cracking and discolouration of steel or enamel finishes.

PLEASE COMPLETE AND RETAIN THIS SECTION FOR YOUR RECORDS

Purchased from:
Address:
Date of Purchase: