

i30-X Freestanding Assembly Instructions



These instructions are to be used in conjunction with the general i30-X installation manual that is shipped with the unit.

DO NOT PLACE ARTICLES ON OR AGAINST THIS APPLIANCE
DO NOT USE OR STORE FLAMMABLE MATERIALS NEAR THIS APPLIANCE
DO NOT SPRAY AEROSOLS IN THE VICINITY OF THIS APPLIANCE WHILE IT IS IN OPERATION
DO NOT MODIFY THIS APPLIANCE

Further information can be found at:
jetmaster.com.au

i30-X Freestanding case Components

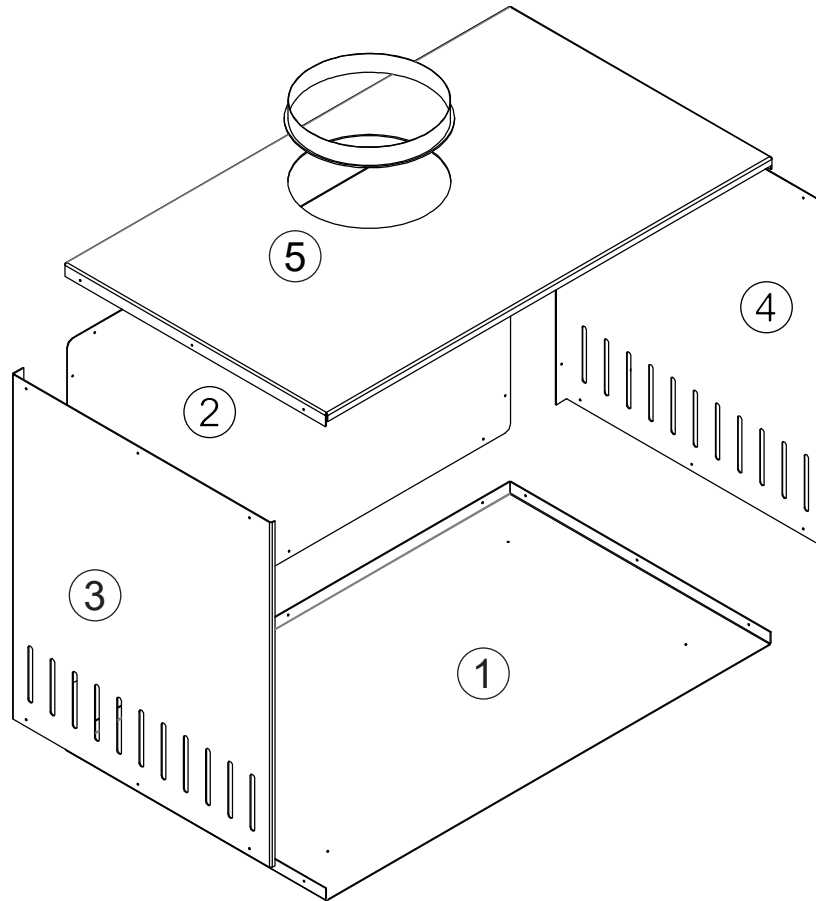

Ref	Description	QTY
1	Base	1
2	Rear Panel	1
3	Left Panel	1
4	Right Panel	1
5	Top Panel - spigot attached	1
6	Black self tapping screws (Pack of 30) - discard	1
7	Rivets (Pack of 30)	1
8	Ceiling Ring	1
9	Plastic gromet	



The fireplace will require the I30X flex liner flue kit together with 8inch solid flue to encase the flexible flue up to the cowl. More information on page 7

i30-X Base - Linear and Stretch Components

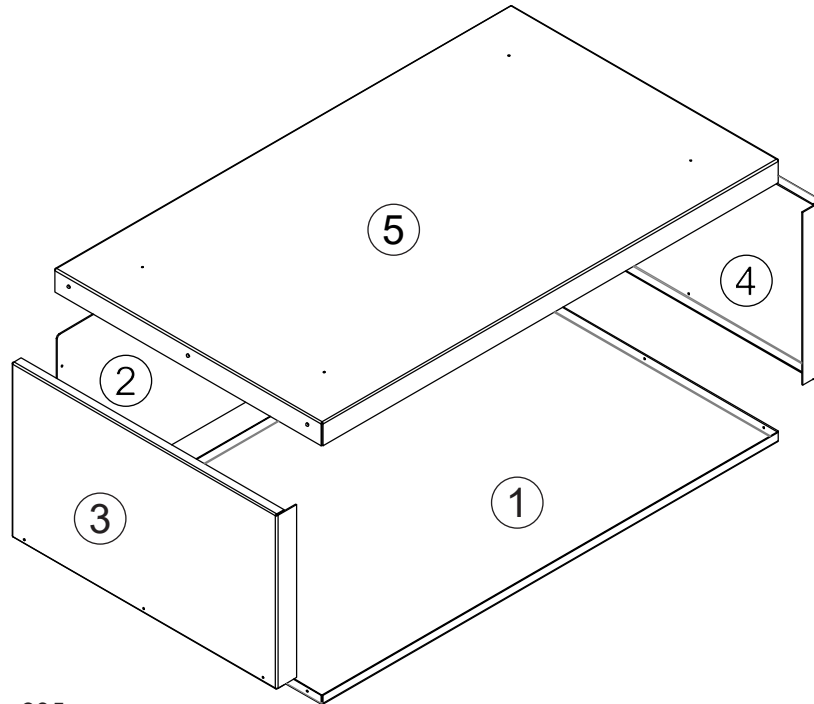

Linear pedestal width - 805mm
Stretch pedestal width - 1105mm

Ref	Description	QTY
1	Base	1
2	Rear Panel	1
3	Left Panel	1
4	Right Panel	1
5	Top Panel	1
6	Black Rivets (pack of 30)	1
7	Nuts for securing top panel to sides	6
8	Black self tapping screws (Pack of 30) - DISCARD	



NOTE: If installing the fireplace on either the linear or stretch base, assemble the base first and then assemble the casing on top. There are 4 locating holes on both part #5 (top panel of the base) and part #1 of the freestanding case that should be used to secure the two together using the supplied screws



i30-X Linear and stretch base Assembly instructions



Materials required:

1. Cordless drill
2. 1/8 drill bit
3. Rivet gun

Step 1.

Unbox the base and identify each component using the table on page 3.

Step 2.

Locate and position the top panel on a clean and flat surface upside down.

The side panels are attached using the supplied nuts (x6) which are fixed to captive welded bolts on the inside of the top panel.



Step 3.

Identify the left and right side panels. Each side panel will have a larger return on the front side and bolt holes that line up to the top panel captive bolts.

Fit the side panels one at a time by positioning them onto the top panel first and sliding on to the captive bolts. Then tighten the nuts as shown.

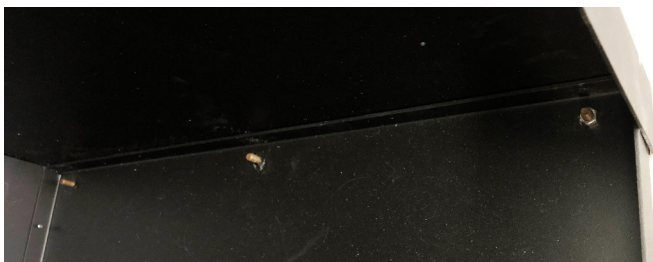

Step 4.

Locate and position the rear panel.

The panel will fit between the base vertical return and is fixed in place using the supplied black rivets

NOTE: A 1/8 size drill bit (not included) will be required to enlarge pilot holes and ensure correct and alignment of each panel

Step 5.

Locate and secure the base panel.

Once the base is secured, flip the base back over to begin assembly of the case.



i30-X Freestanding case Assembly instructions



Materials required:

1. Cordless drill
2. 1/8 drill bit
3. Rivet gun

Step 1.

Unbox the freestanding case and identify each component using page 2 as reference.

Step 2.

Locate and position the base panel on a flat and slightly elevated working surface. The base panel front is the flat edge.

If using one of the matching bases (linear or stretch) fix this panel to the top of the base using the 4 pre-drilled holes now.

Step 3.

Locate and position the rear panel on the inside lip of the base panel and line up the pre-drilled holes.

IMPORTANT: *The cut outs for the gas and power should be on the left side when facing the unit to correspond with the i30X unit.*

Open up the middle pilot hole with a 1/8 size drill and rivet together with the supplied black rivets. Then do the same with the other two pilot holes.

Step 4.

IMPORTANT: *drill out and rivet each pilot hole **one at a time** to ensure correct alignment and fitment.*

Locate and identify the left and right side panels. They will have a large return with pre-drilled holes to attach to the back panel with vertical linear slots at the bottom when positioned correctly.

Fit the side panels one at a time by positioning them to the inside lip of the base panel and against the back panel.

Drill and rivet each pilot hole on the base and rear panel.

IMPORTANT: *Do not rivet the top pilot holes until after the top panel is in position to ensure ease of fitment*



i30-X Freestanding case Assembly instructions



Step 5.
Position the top panel in place and line up the pre-drilled holes.

Step 6.
Rivet the top panel into place starting with both front locations. Pinch the side panel against the lid to ensure the rivet attaches adequately.

Complete all remaining rivet points on the top and back panel, then position in the desired location for unit installation.
Fix the base to the floor using relevant materials.

Clearance requirements

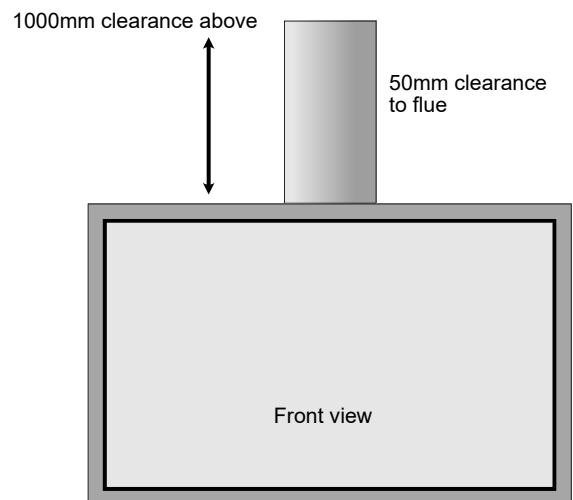
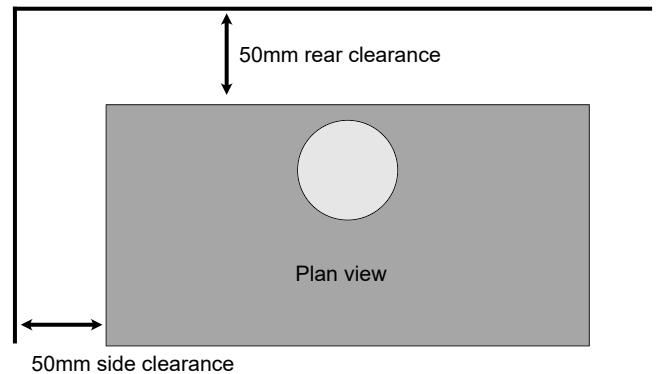

Zero clearance required under the casing
Refer to current i30-X AU manual for floor protection requirements

i30-X Freestanding case Assembly instructions

Optional shielding if required

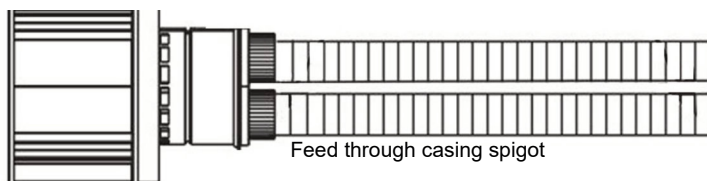
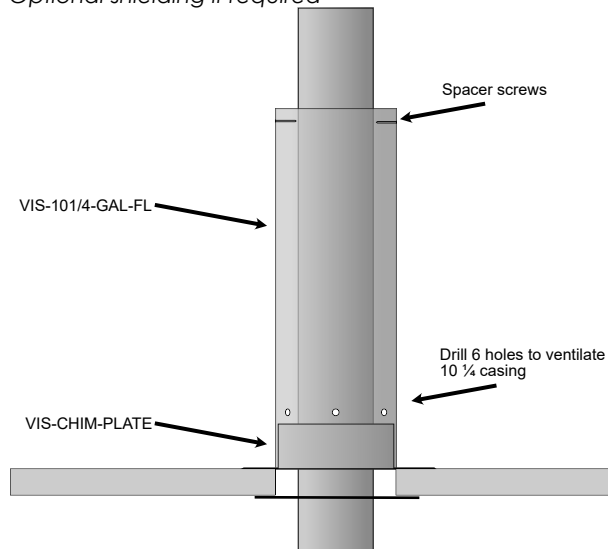

Step 7.

Mark the ceiling for the flue penetration using a plumb bob or laser guide and rivet together the unpainted 8inch gal. If the exposed flue requires fixing, black rivets are recommended.

NOTE: Do not use screws as they can damage the flexible flue.

Step 8.

Install the flue maintaining 50mm clearance to combustible material through ceiling space and connect over to the freestanding case spigot.

Use the supplied ceiling ring to cover the ceiling penetration gap and affix with hi temp silicone.

If the 8inch solid flue is passing through a ceiling space, storage area or a location where blow-in insulation is used, add an additional 10 1/4 ventilated flue pipe (cut to required size) and a locating plate to maintain the required 25mm clearance to the 8inch pipe. Use 15mm self tapping screws to ensure spacing is consistent. Drill 6 holes at the base of the outer pipe to ventilate the casing. This must be left open at the top.

Step 9.

Feed the flexible flue down through the solid 8inch pipe and connect to the removable spigot as per below inside the free standing case.

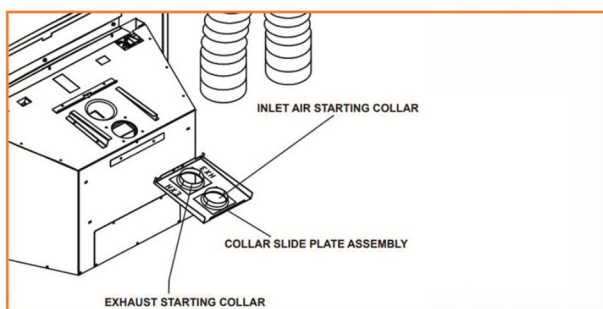
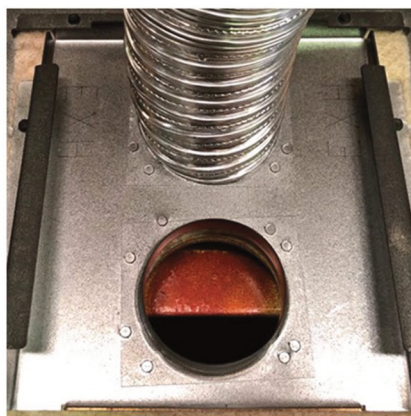

Connecting Vent Pipe

Reference instructions in the termination kit

- Install the two 3" flexi flue pipe(s) down through the gal flue pipe
- Secure each of the pipes to the starter collars using 3 self tapping screws on each

Note: The collar slide plate may be removed from the unit to aid installation - please see instruction manual

i30-X Freestanding case Assembly instructions



It is recommended that the bottom 100mm of the i30X unit is sprayed with hi-temp black paint prior to fitting to the freestanding case. This is to ensure no silver metal is visible through the ventilation slots on the side of the free standing casing.

Step 10.

Position the i30-X fireplace into the casing on an angle so as to be able to feed both the flexible gas line and power cord through the back panel.

Feed the flexible gas line out through the rear panel rectangular hole and the power cord through the fold out tab. Ensure to use the supplied gromet to protect the power cord.

Step 11.

Straighten the unit within the casing and connect the flexible flue slide plate assembly to the unit whilst pushing the unit into the casing. Screw in and tighten the slide plate locking screw.

Step 12.

Connect gas and power and follow the commissioning procedures for the fireplace outlined in the general installation instructions.

The DF front assembly is used to finish the final product. The unit should be positioned and lined up so the decorative front assembly is centered and flush with the outer casing.

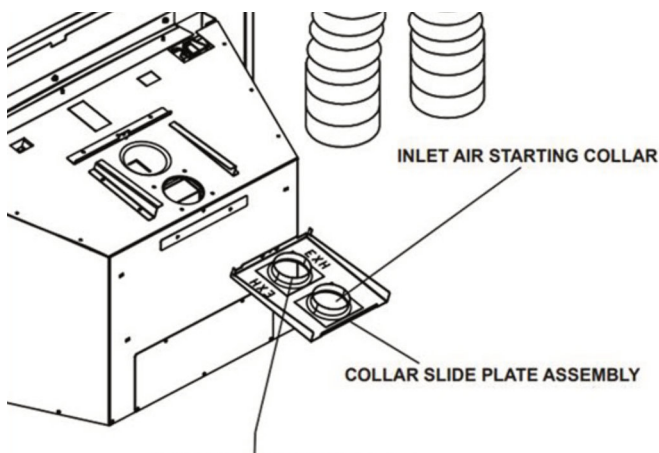

i30-X Free Standing

Install Instructions Straight Flue Run

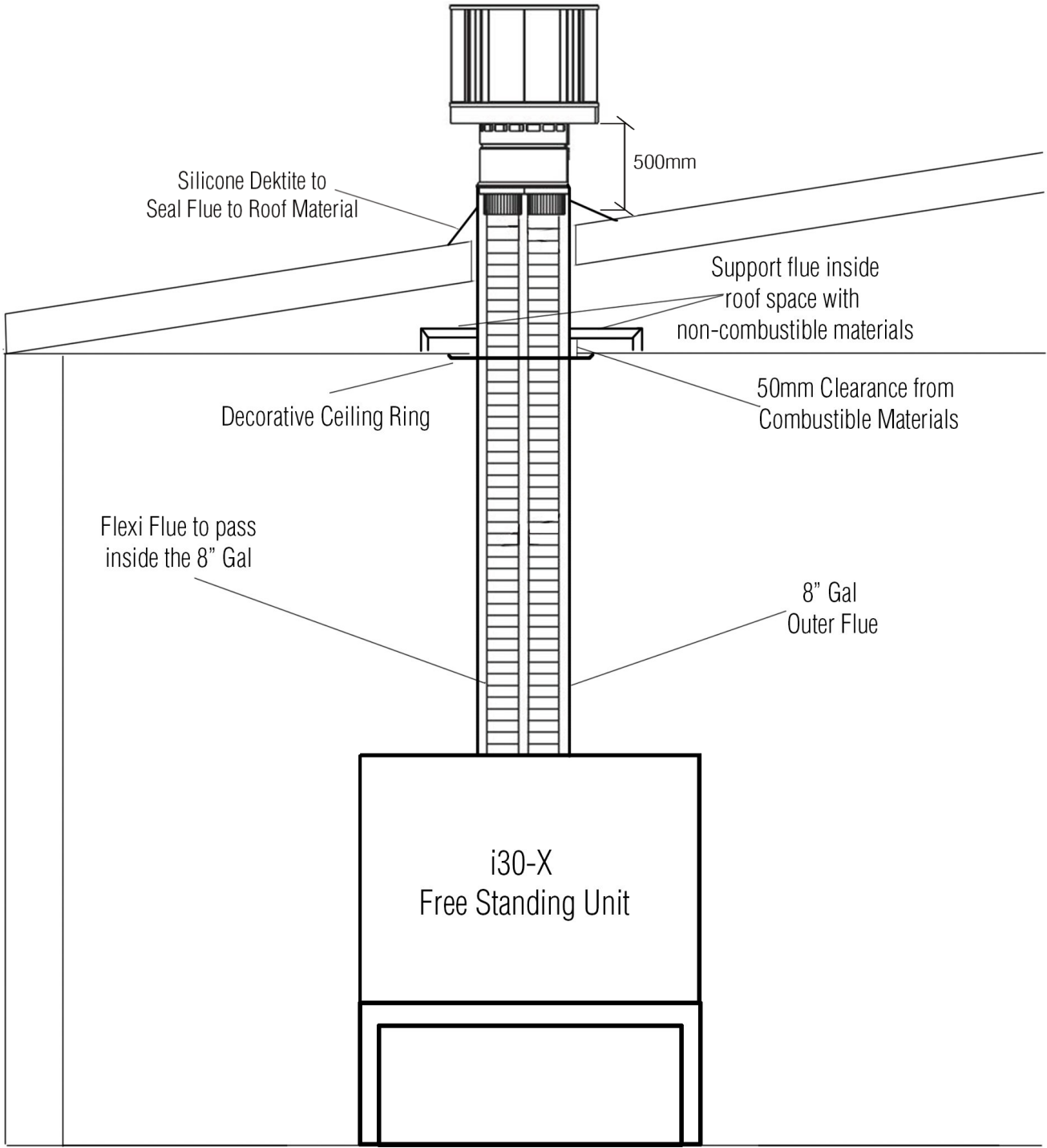

i30-X Free Standing

Install Instructions

Offset Flue Run

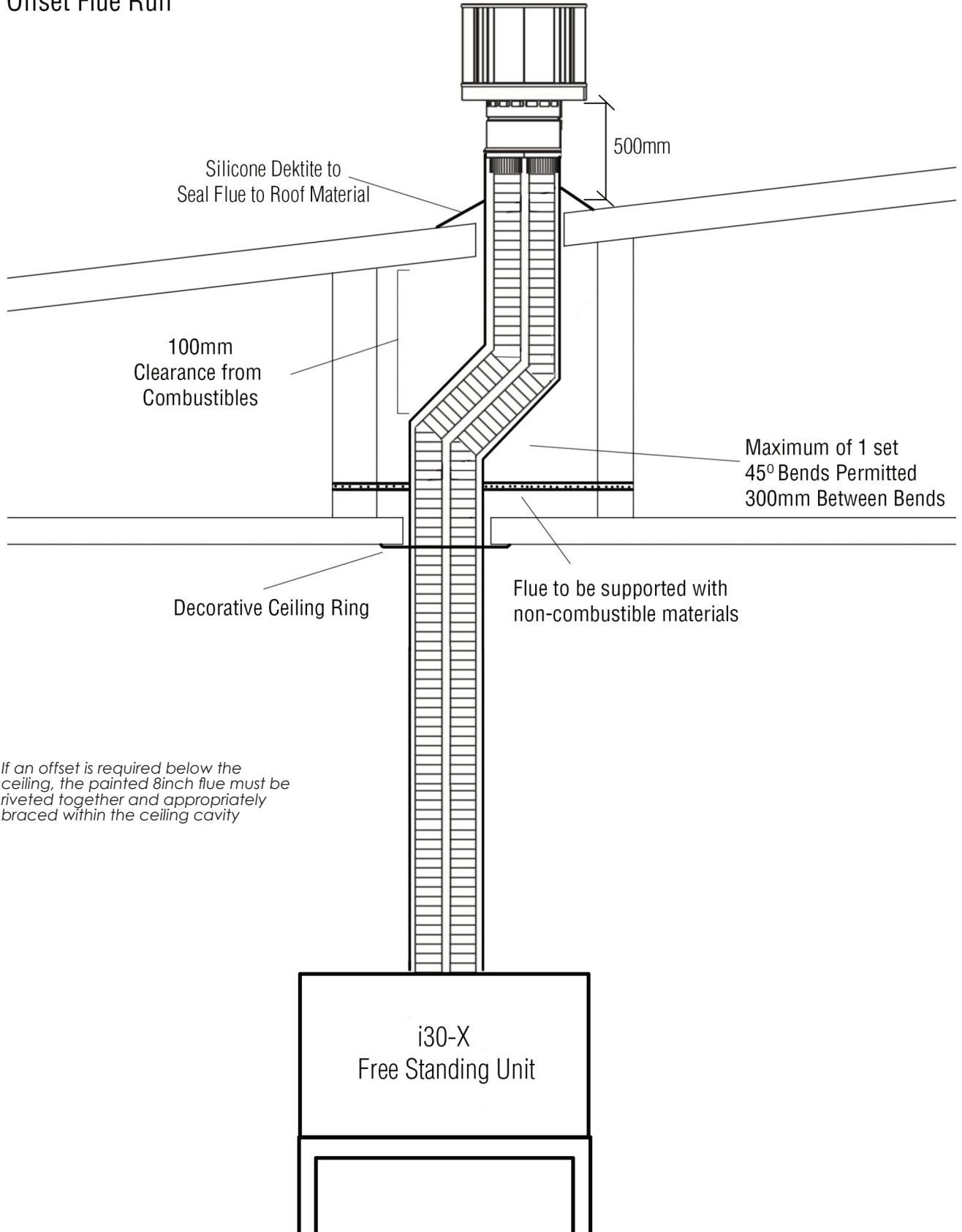

i30-X Freestanding Unit Dimensions

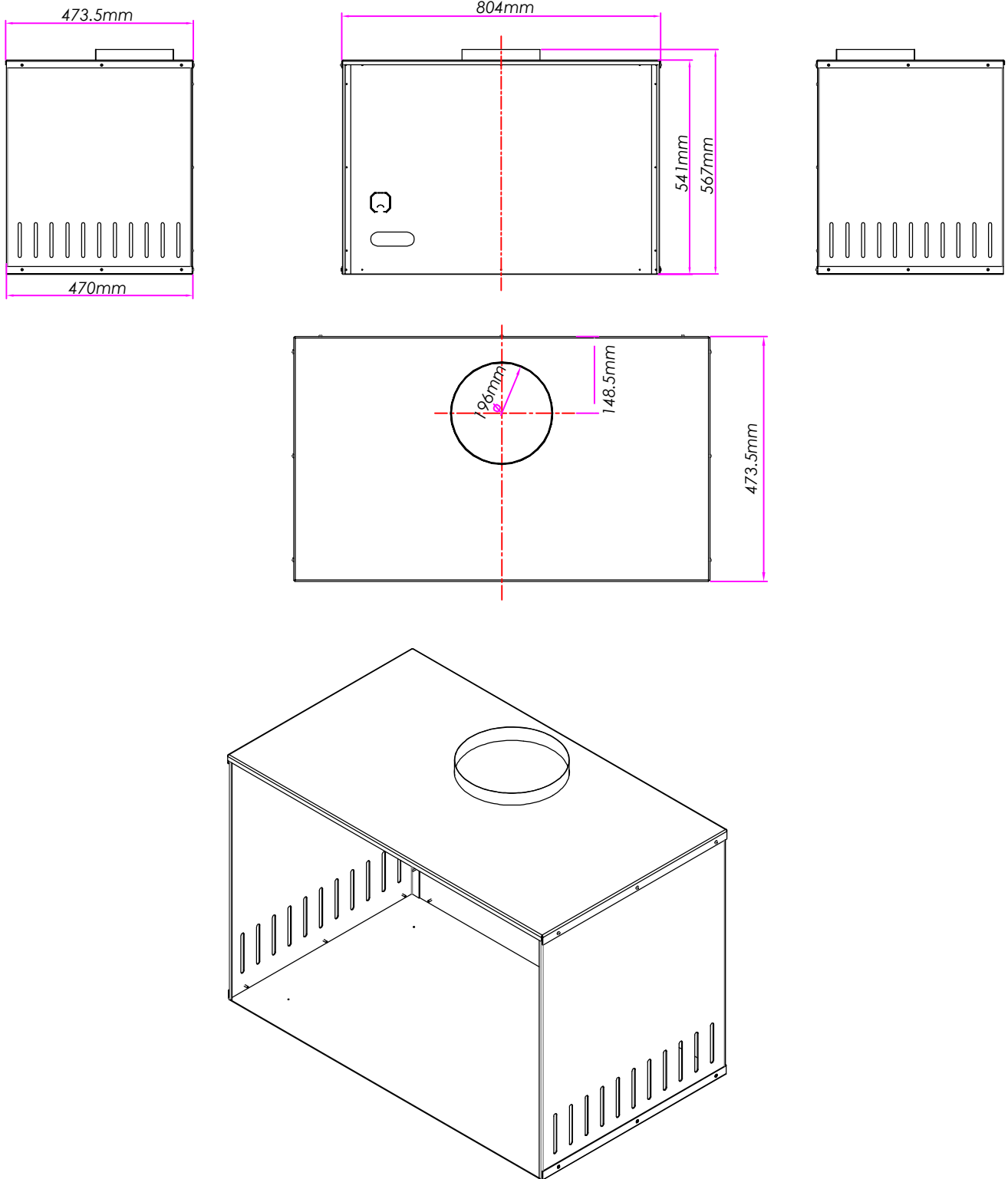

i30-X Freestanding Base Dimensions

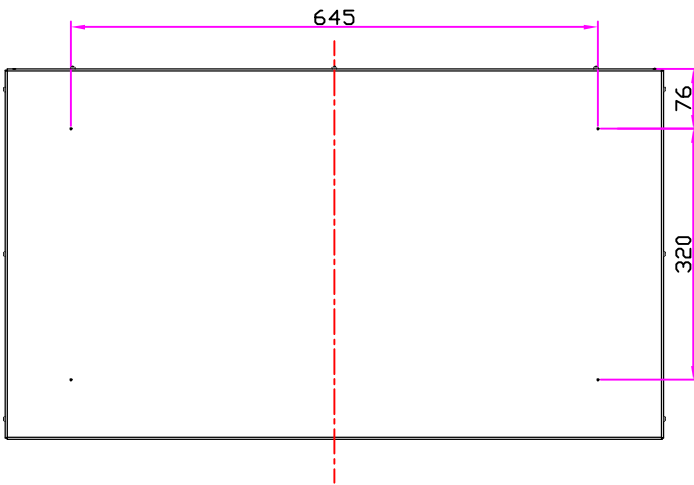
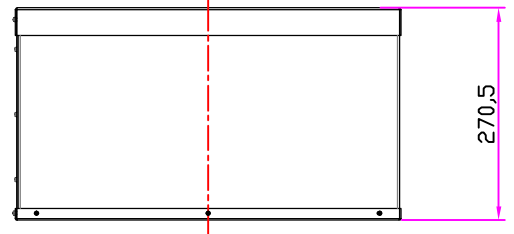
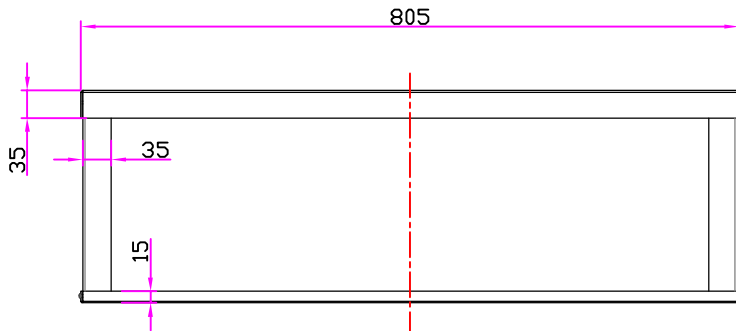

LINEAR BASE

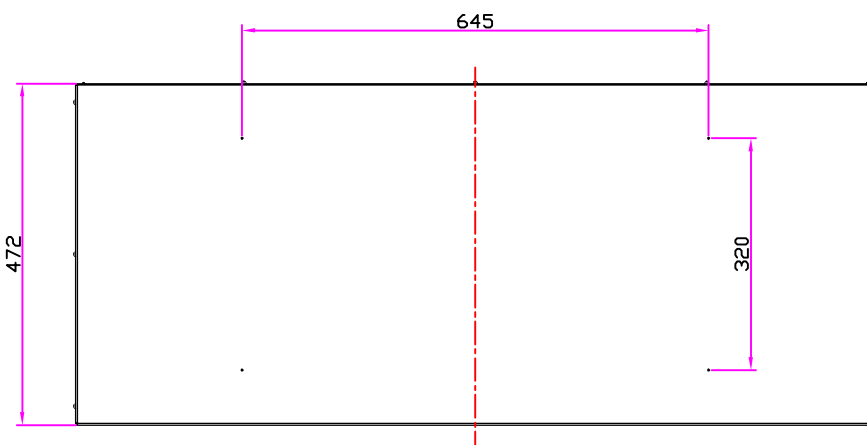
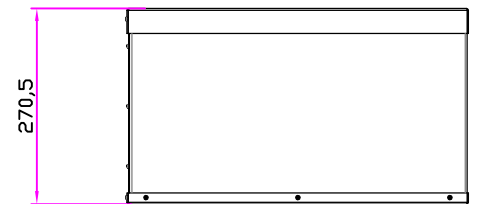
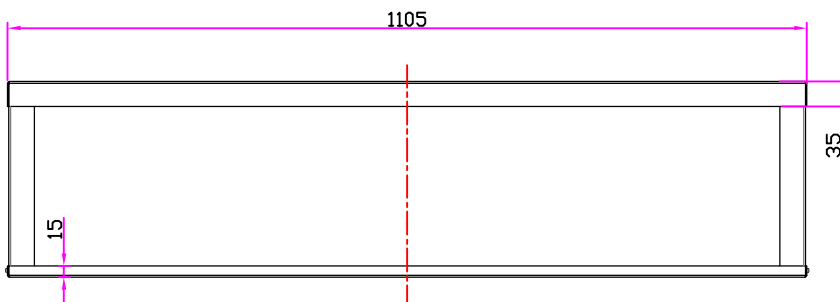

STRETCH BASE



HEAT & GLO™

Jetmaster Fireplaces Australia

55 Marrickville Road, Marrickville, NSW 2204
13 French Ave, Brendale QLD 4500

PH: 1300 538 627
www.jetmaster.com.au